

VAV terminal units

Type TVJ



Universal controller



Compact controller



Easy controller

For normal and high volume flow rate ranges

Rectangular VAV terminal units for standard applications regarding the supply air or extract air control in variable air volume systems

- For volume flow rate ranges up to 36,000 m³/h or 10,000 l/s
- Suitable for the control of volume flow rate, room pressure or duct pressure
- Electronic control components for different applications (Easy, Compact, Universal, and LABCONTROL)
- High control accuracy
- Suitable for airflow velocities up to 10 m/s
- Casing air leakage to EN 1751, class B

Optional equipment and accessories

- Acoustic cladding for the reduction of case-radiated noise
- Secondary silencer Type TX for the reduction of air-regenerated noise
- Hot water heat exchanger of Type WT for reheating the airflow

Type		Page
TVJ	General information	TVJ – 2
	Function	TVJ – 4
	Technical data	TVJ – 5
	Quick sizing	TVJ – 10
	Specification text	TVJ – 15
	Order code	TVJ – 16
	Variants	TVJ – 19
	Attachments	TVJ – 20
	Dimensions and weight	TVJ – 22
	Installation details	TVJ – 26
	Basic information and nomenclature	TVJ – 29

Application

Application

- Rectangular VARYCONTROL VAV terminal units of Type TVJ for the precise supply air or extract air flow control in variable air volume systems
- Closed-loop volume flow control using an external power supply
- For controlling, restricting, or shutting off the airflow in air conditioning systems

Special characteristics

- Integral differential pressure sensor with 3 mm

measuring holes (resistant to dust and pollution)

- Factory set-up or programming and aerodynamic function testing
- Volume flow rate can be measured and subsequently adjusted on site; additional adjustment tool may be necessary

Nominal sizes

- 39 nominal sizes from 200 × 100 to 1000 × 1000

Description

Variants

- TVJ: VAV terminal unit
- TVJ-D: VAV terminal unit with acoustic cladding
- Units with acoustic cladding and/or secondary silencer Type TX for demanding acoustic requirements
- Acoustic cladding cannot be retrofitted

Construction

- Galvanised sheet steel
- P1: Powder-coated, silver grey (RAL 7001)

Parts and characteristics

- Ready-to-commission unit which consists of mechanical parts and control components.
- Averaging differential pressure sensor for volume flow rate measurement
- Damper blades
- Factory-assembled control components complete with wiring and tubing
- Aerodynamic function testing on a special test rig prior to shipping of each unit
- Set-up data is given on a label or volume flow rate scale affixed to the unit
- High volume flow rate control accuracy

Attachments

- Easy controller: Compact unit consisting of controller with potentiometers, differential pressure transducer and actuator
- Compact controller: Compact unit consisting of controller, differential pressure transducer and actuator
- Universal controller: Controller, differential

pressure transducer and actuators for special applications

- LABCONTROL: Control components for air management systems

Useful additions

- Secondary silencer Type TX for demanding acoustic requirements
- Heat exchanger Type WT

Construction features

- Rectangular casing
- Flanges on both sides, suitable for duct connection
- Opposed blade action, blades connected by internal gears at both ends
- Position of the damper blade indicated externally at shaft extension
- Bearings with ring seals

Materials and surfaces

Galvanised sheet steel construction

- Casing made of galvanised sheet steel
- Shafts made of galvanised steel
- Damper blades and differential pressure sensor made of aluminium
- Gears made of anti-static plastic (ABS), heat resistant to 50 °C
- Plastic bearings

Powder-coated construction (P1)

- Casing made of galvanised sheet steel, powder-coated

Variant with acoustic cladding (-D)

- Acoustic cladding made of galvanised sheet steel
- Rubber profile for the insulation of structure-borne noise
- Lining is mineral wool

Mineral wool

- To EN 13501, fire rating class A1, non-combustible
- RAL quality mark RAL-GZ 388
- Biosoluble and hence hygienically safe

according to the German TRGS 905 (Technical Rules for Hazardous Substances) and EU directive 97/69/EG

Standards and guidelines

- Casing air leakage to EN 1751, class B

Maintenance

- Maintenance-free as construction and materials are not subject to wear

Functional description

The VAV terminal unit is fitted with a differential pressure sensor for measuring the volume flow rate.

The control components (attachments) include a differential pressure transducer that transforms the differential pressure (effective pressure) into an electric signal, a controller, and an actuator; the control functions can be achieved with an Easy

controller, with a Compact controller, or with individual components (Universal or LABCONTROL).

For most applications, the setpoint value comes from a room temperature controller.

The controller compares the actual value with the setpoint value and alters the control signal of the actuator if there is a difference between the two values.

Schematic illustration of the TVJ

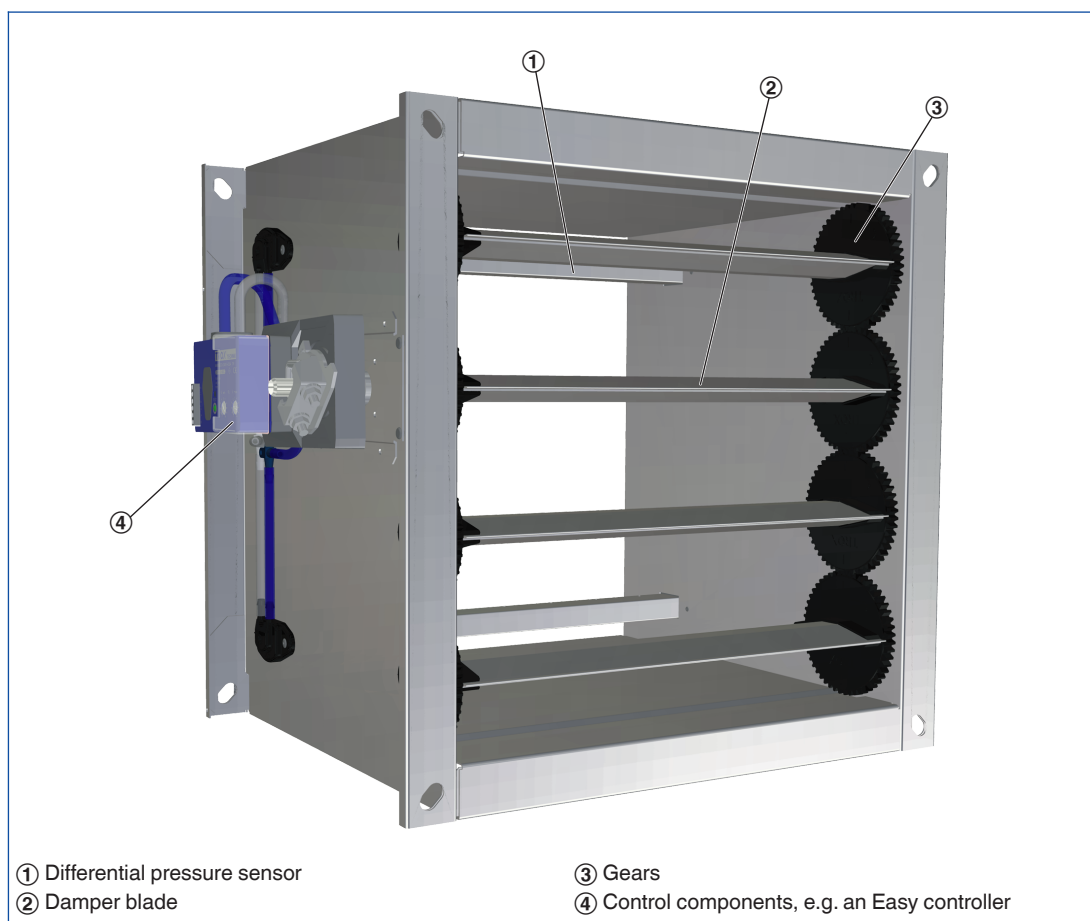

Nominal sizes	200 × 100 to 1000 × 1000 mm
Volume flow rate range	45 – 10100 l/s or 162 – 36360 m ³ /h
Volume flow rate control range (unit with dynamic differential pressure measurement)	Approx. 20 to 100 % of the nominal volume flow rate
Minimum differential pressure	5 – 40 Pa
Maximum differential pressure	1000 Pa
Operating temperature	10 – 50 °C

Volume flow rate ranges

The minimum differential pressure of VAV terminal units is an important factor in designing the ductwork and in rating the fan including speed control.

Sufficient duct pressure must be ensured for all operating conditions and for all control units. The measurement points for fan speed control must be selected accordingly.

The volume flow rates given for VAV terminal units

depend on the nominal size and on the control component (attachment) that is installed. The table gives the minimum and maximum values for a VAV terminal unit. Some control components may only have a limited volume flow rate range. This applies in particular to control components with a static differential pressure transducer. For volume flow rate ranges for all control components refer to our Easy Product Finder design programme.

TVJ, Volume flow rate ranges and minimum differential pressures

Nominal size	①	②	$\Delta p_{st \min}$		$\Delta \dot{V}$
	\dot{V}		Pa		$\pm \%$
	l/s	m ³ /h	Pa	Pa	
200 × 100	45	162	5	10	14
	85	306	10	25	8
	150	540	20	80	5
	215	774	40	155	5
300 × 100	65	234	5	10	14
	120	432	10	25	8
	210	756	20	70	5
	320	1152	40	155	5
400 × 100	85	306	5	10	14
	170	612	10	25	8
	300	1080	20	80	5
	425	1530	40	155	5
500 × 100	105	378	5	10	14
	200	720	10	25	8
	350	1260	20	70	5
	535	1926	40	155	5
600 × 100	130	468	5	10	14
	260	936	10	25	8
	450	1620	20	75	5
	650	2340	40	155	5
200 × 200	85	306	5	10	14
	160	576	10	25	8
	280	1008	20	75	5
	415	1494	40	155	5
300 × 200	125	450	5	10	14
	240	864	10	25	8
	420	1512	20	75	5
	620	2232	40	155	5
400 × 200	165	594	5	10	14
	330	1188	10	25	8
	580	2088	20	80	5
	825	2970	40	155	5
500 × 200	205	738	5	10	14
	400	1440	10	25	8
	700	2520	20	75	5
	1035	3726	40	155	5
600 × 200	250	900	5	10	14
	500	1800	10	25	8
	870	3132	20	80	5
	1250	4500	40	155	5
700 × 200	290	1044	5	10	14
	560	2016	10	25	8
	980	3528	20	75	5
	1450	5220	40	155	5
800 × 200	330	1188	5	10	14
	660	2376	10	25	8
	1160	4176	20	80	5
	1650	5940	40	155	5

① TVJ

② TVJ with secondary silencer TX

TVJ, Volume flow rate ranges and minimum differential pressures

Nominal size	①	②	$\Delta p_{st \min}$		$\Delta \dot{V}$
	\dot{V}		Pa		$\pm \%$
	l/s	m ³ /h	Pa	Pa	
300 × 300	185	666	5	10	14
	360	1296	10	25	8
	630	2268	20	75	5
	920	3312	35	150	5
400 × 300	245	882	5	10	14
	480	1728	10	25	8
	840	3024	20	70	8
	1230	4428	35	150	5
500 × 300	305	1098	5	10	14
	600	2160	10	25	8
	1050	3780	20	70	5
	1535	5526	35	150	5
600 × 300	370	1332	5	10	14
	740	2664	10	25	8
	1290	4644	20	75	5
	1850	6660	35	150	5
700 × 300	430	1548	5	10	14
	840	3024	10	25	8
	1470	5292	20	70	5
	2150	7740	35	150	5
800 × 300	490	1764	5	10	14
	980	3528	10	25	8
	1720	6192	20	75	5
	2450	8820	35	150	5
900 × 300	555	1998	5	10	14
	1080	3888	10	25	8
	1890	6804	20	70	5
	2770	9972	35	150	5
1000 × 300	620	2232	5	10	14
	1240	4464	10	25	8
	2150	7740	20	75	5
	3100	11160	35	150	5
400 × 400	325	1170	5	10	14
	640	2304	10	25	8
	1120	4032	20	75	5
	1630	5868	35	150	5
500 × 400	410	1476	5	10	14
	800	2880	10	25	8
	1400	5040	20	75	5
	2040	7344	35	150	5
600 × 400	490	1764	5	10	14
	980	3528	10	25	8
	1720	6192	20	75	5
	2450	8820	35	150	5
700 × 400	570	2052	5	10	14
	1120	4032	10	25	8
	1960	7056	20	75	5
	2850	10260	35	150	5

① TVJ

② TVJ with secondary silencer TX

TVJ, Volume flow rate ranges and minimum differential pressures

Nominal size	①	②			$\Delta\dot{V}$ ± %
	\dot{V}		$\Delta p_{st\ min}$		
	l/s	m ³ /h	Pa	Pa	
800 × 400	650	2340	5	10	14
	1300	4680	10	25	8
	2280	8208	20	75	5
	3250	11700	35	150	5
900 × 400	735	2646	5	10	14
	1440	5184	10	25	8
	2520	9072	20	75	5
	3670	13212	35	150	5
1000 × 400	820	2952	5	10	14
	1640	5904	10	25	8
	2850	10260	20	75	5
	4100	14760	35	150	5
500 × 500	510	1836	5	10	14
	1000	3600	10	25	8
	1750	6300	20	75	5
	2540	9144	40	155	5
600 × 500	610	2196	5	10	14
	1200	4320	10	25	8
	2100	7560	20	75	5
	3050	10980	40	155	5
700 × 500	710	2556	5	10	14
	1400	5040	10	25	8
	2450	8820	20	75	5
	3550	12780	40	155	5
800 × 500	810	2916	5	10	14
	1600	5760	10	25	8
	2800	10080	20	75	5
	4050	14580	40	155	5
900 × 500	915	3294	5	10	14
	1800	6480	10	25	8
	3150	11340	20	75	5
	4570	16452	40	155	5

① TVJ

② TVJ with secondary silencer TX

TVJ, Volume flow rate ranges and minimum differential pressures

Nominal size	①	②	$\Delta p_{st \min}$		$\Delta \dot{V}$
	\dot{V}		Pa		$\pm \%$
	l/s	m ³ /h	Pa	Pa	
1000 × 500	1020	3672	5	10	14
	2000	7200	10	25	8
	3500	12600	20	75	5
	5100	18360	40	155	5
600 × 600	730	2628	5	10	14
	1440	5184	10	25	8
	2520	9072	20	75	5
	3650	13140	40	155	5
800 × 600	970	3492	5	10	14
	1920	6912	10	25	8
	3360	12096	20	75	5
	4850	17460	40	155	5
1000 × 600	1220	4392	5	10	14
	2400	8640	10	25	8
	4200	15120	20	75	5
	6100	21960	40	155	5
800 × 800	1300	4680	5	10	14
	2560	9216	10	25	8
	4480	16128	20	75	5
	6500	23400	40	155	5
1000 × 800	1620	5832	5	10	14
	3200	11520	10	25	8
	5600	20160	20	75	5
	8100	29160	40	155	5
1000 × 1000	2020	7272	5	10	14
	4000	14400	10	25	8
	7000	25200	20	75	5
	10100	36360	40	155	5

① TVJ

② TVJ with secondary silencer TX

Quick sizing tables provide a good overview of the room sound pressure levels that can be expected. Approximate intermediate values can be interpolated. Precise intermediate values and spectral data can be calculated with our Easy Product Finder design programme.

The first selection criteria for the nominal size are the actual volume flow rates \dot{V}_{\min} and \dot{V}_{\max} . The quick sizing tables are based on generally accepted attenuation levels. If the sound pressure level exceeds the required level, a larger air terminal unit and/or a silencer is required.

Quick sizing: Sound pressure level at differential pressure 150 Pa

Nominal size	\dot{V}	\dot{V}	Air-regenerated noise		Case-radiated noise	
			①	②	①	③
	l/s	m ³ /h	L _{PA}	L _{PA1}	L _{PA2}	L _{PA3}
dB(A)						
200 x 100	45	162	43	17	31	19
	85	306	47	26	35	24
	150	540	49	36	38	29
	215	774	49	41	41	33
300 x 100	65	234	44	18	32	20
	120	432	47	27	35	25
	210	756	48	34	38	30
	320	1152	48	40	41	34
400 x 100	85	306	45	20	33	21
	170	612	47	28	37	27
	300	1080	47	35	40	32
	425	1530	48	40	43	36
500 x 100	105	378	46	20	34	22
	200	720	47	28	37	27
	350	1260	47	34	41	32
	535	1926	48	40	44	37
600 x 100	130	468	46	22	34	22
	260	936	47	28	38	29
	450	1620	47	35	42	34
	650	2340	48	39	45	37
200 x 200	85	306	45	20	33	21
	160	576	48	28	36	26
	280	1008	48	35	41	32
	415	1494	49	40	43	36
300 x 200	125	450	46	21	34	22
	240	864	47	27	37	27
	420	1512	48	34	41	33
	620	2232	48	39	44	37
400 x 200	165	594	46	22	35	23
	330	1188	46	27	38	29
	580	2088	47	34	43	35
	825	2970	48	39	46	39
500 x 200	205	738	46	22	36	24
	400	1440	46	27	39	30
	700	2520	47	34	44	36
	1035	3726	48	39	47	40
600 x 200	250	900	46	22	36	25
	500	1800	46	27	40	31
	870	1800	47	34	45	37
	1250	4500	47	39	47	41
700 x 200	290	1044	46	22	37	25
	560	2016	46	27	40	31
	980	3528	47	34	45	38
	1450	5220	47	39	48	42
800 x 200	330	1188	46	22	37	26
	660	2376	46	27	41	32
	1160	4176	47	34	46	38
	1650	5940	47	39	49	42

- ① TVJ
- ② TVJ with secondary silencer TX
- ③ TVJ-D

Quick sizing: Sound pressure level at differential pressure 150 Pa

Nominal size	\dot{V}	\dot{V}	Air-regenerated noise		Case-radiated noise	
			①	②	①	③
			L _{PA}	L _{PA1}	L _{PA2}	L _{PA3}
	l/s	m ³ /h	dB(A)			
300 x 300	185	666	46	21	35	23
	360	1296	46	26	39	29
	630	2268	47	33	43	35
	920	3312	47	39	46	39
400 x 300	245	882	46	21	36	24
	480	1728	46	27	40	30
	840	3024	46	33	44	37
	1230	4428	47	39	47	41
500 x 300	305	1098	46	22	67	25
	600	2160	46	27	41	31
	1050	3780	47	33	45	38
	1535	5526	47	39	48	42
600 x 300	370	1332	46	22	37	26
	740	2664	46	27	42	32
	1290	4644	47	33	46	39
	1850	6660	47	39	49	42
700 x 300	430	1548	46	22	38	27
	840	3024	46	27	42	33
	1470	5292	46	33	47	40
	2150	7740	47	39	50	43
800 x 300	490	1764	45	22	38	27
	980	3528	46	27	43	34
	1720	6192	46	33	47	40
	2450	8820	47	39	50	44
900 x 300	555	1998	46	22	39	28
	1080	3888	46	27	43	34
	1890	6804	46	33	48	41
	2770	9972	47	39	51	44
1000 x 300	620	2232	45	22	39	28
	1240	4464	46	28	44	35
	2150	7740	46	33	48	41
	3100	11160	47	38	51	45
400 x 400	325	1170	45	21	37	26
	640	2304	46	27	41	31
	1120	4032	46	34	45	37
	1630	5868	47	40	49	42
500 x 400	410	1476	45	21	38	27
	800	2880	46	27	42	32
	1400	5040	46	34	46	38
	2040	7344	47	40	50	43
600 x 400	490	1764	45	21	38	27
	980	3528	46	27	43	33
	1720	6192	46	34	47	40
	2450	8820	47	39	50	44
700 x 400	570	2052	45	22	39	28
	1120	4032	46	27	43	34
	1960	7056	46	33	48	40
	2850	10260	47	39	51	44

- ① TVJ
- ② TVJ with secondary silencer TX
- ③ TVJ-D

Quick sizing: Sound pressure level at differential pressure 150 Pa

Nominal size	\dot{V}	\dot{V}	Air-regenerated noise		Case-radiated noise	
			①	②	①	③
	l/s	m ³ /h	L _{PA}	L _{PA1}	L _{PA2}	L _{PA3}
dB(A)						
800 x 400	650	2340	45	22	39	28
	1300	4680	45	27	44	35
	2280	8208	46	33	48	41
	3250	11700	47	39	51	45
900 x 400	735	2646	45	22	40	29
	1440	5184	46	26	44	35
	2520	9072	46	33	49	41
	3670	13212	47	39	52	46
1000 x 400	820	2952	45	22	40	29
	1640	5904	45	27	44	36
	2850	10260	46	33	49	42
	4100	14760	47	38	52	46
500 x 500	510	1836	45	21	38	27
	1000	3600	46	26	43	33
	1750	6300	46	33	47	39
	2540	9144	47	39	50	44
600 x 500	610	2196	45	21	39	28
	1200	4320	46	26	43	34
	2100	7560	46	33	48	40
	3050	10980	47	39	51	44
700 x 500	710	2556	45	21	39	29
	1400	5040	46	27	44	35
	2450	8820	46	33	48	41
	3550	12780	47	39	52	45
800 x 500	810	2916	45	22	40	29
	1600	5760	45	27	44	36
	2800	10080	46	33	49	42
	4050	14580	47	39	52	46
900 x 500	915	3294	45	21	40	30
	1800	6480	46	27	45	36
	3150	11340	46	33	50	42
	4570	16452	47	39	53	47
1000 x 500	1020	3672	44	22	41	30
	2000	7200	45	27	45	37
	3500	12600	46	33	50	43
	5100	18360	46	38	53	47
600 x 600	730	2628	45	21	40	28
	1440	5184	45	27	44	35
	2520	9072	46	33	49	41
	3650	13140	46	39	52	45
800 x 600	970	3492	45	22	41	30
	1920	6912	45	27	45	36
	3360	12096	46	33	50	43
	4850	17460	46	39	53	47
1000 x 600	1220	4392	45	22	41	31
	2400	8640	45	27	46	37
	4200	15120	46	33	51	44
	6100	21960	46	38	54	48

- ① TVJ
- ② TVJ with secondary silencer TX
- ③ TVJ-D

Quick sizing: Sound pressure level at differential pressure 150 Pa

Nominal size	\dot{V}	\dot{V}	Air-regenerated noise		Case-radiated noise	
			①	②	①	③
			L _{PA}	L _{PA1}	L _{PA2}	L _{PA3}
	l/s	m ³ /h	dB(A)			
800 x 800	1300	4680	44	21	42	31
	2560	9216	45	27	47	38
	4480	16128	46	33	51	44
	6500	23400	46	39	55	49
1000 x 800	1620	5832	44	21	42	32
	3200	11520	45	26	47	39
	5600	20160	46	33	52	45
	8100	29160	46	39	55	49
1000 x 1000	2020	7272	44	21	43	33
	4000	14400	45	26	48	40
	7000	25200	45	33	53	46
	10100	36360	46	39	57	51

- ① TVJ
- ② TVJ with secondary silencer TX
- ③ TVJ-D

This specification text describes the general properties of the product. Texts for variants can be generated with our Easy Product Finder design programme.

Rectangular VAV terminal units for variable and constant air volume systems, suitable for supply or extract air, available in 39 nominal sizes. High volume flow rate control accuracy. Ready-to-commission unit which consists of the mechanical parts and the electronic control components. Each unit contains an averaging differential pressure sensor for volume flow rate measurement and damper blades. Factory assembled control components complete with wiring and tubing. Differential pressure sensor with 3 mm measuring holes (resistant to dust and pollution) Both ends suitable for the connection of ducts. Position of the damper blades indicated externally at the shaft extension. Casing air leakage to EN 1751, class B.

Special characteristics

- Integral differential pressure sensor with 3 mm measuring holes (resistant to dust and pollution)
- Factory set-up or programming and aerodynamic function testing
- Volume flow rate can be measured and subsequently adjusted on site; additional adjustment tool may be necessary

Materials and surfaces

Galvanised sheet steel construction

- Casing made of galvanised sheet steel
- Shafts made of galvanised steel
- Damper blades and differential pressure sensor made of aluminium
- Gears made of anti-static plastic (ABS), heat resistant to 50 °C
- Plastic bearings

Powder-coated construction (P1)

- Casing made of galvanised sheet steel, powder-coated

Variant with acoustic cladding (-D)

- Acoustic cladding made of galvanised sheet steel
- Rubber profile for the insulation of structure-borne noise
- Lining is mineral wool

Mineral wool

- To EN 13501, fire rating class A1, non-combustible
- RAL quality mark RAL-GZ 388
- Biosoluble and hence hygienically safe according to the German TRGS 905 (Technical

Rules for Hazardous Substances) and EU directive 97/69/EG

Construction

- Galvanised sheet steel
- P1: Powder-coated, silver grey (RAL 7001)

Technical data

- Nominal sizes: 200 × 100 to 1000 × 1000 mm
- Volume flow rate range: 45 to 10100 l/s or 162 to 36360 m³/h
- Volume flow rate control range (unit with dynamic differential pressure measurement): approx. 20 to 100 % of the nominal volume flow rate
- Minimum differential pressure: 5 – 40 Pa
- Maximum differential pressure: 1000 Pa

Attachments

Variable volume flow control with electronic Easy controller to connect an external control signal; actual value signal can be integrated into the central BMS.

- Supply voltage 24 V AC/DC
- Signal voltages 0 – 10 V DC
- Possible override controls with external switches using volt-free contacts: CLOSED, OPEN, \dot{V}_{\min} and \dot{V}_{\max}
- Potentiometers with percentage scales to set the volume flow rates \dot{V}_{\min} and \dot{V}_{\max}
- The actual value signal relates to the nominal volume flow rate such that commissioning and subsequent adjustment are simplified
- Volume flow rate control range: approx. 20 – 100 % of the nominal volume flow rate
- Clearly visible external indicator light for signalling the functions: Set, not set, and power failure

Electrical connections with screw terminals. Double terminals for looping the supply voltage, i.e. for the simple connection of voltage transmission to the next controller.

Sizing data

- \dot{V} _____ [m³/h]
- Δp_{st} _____ [Pa]

Air-regenerated noise

- L_{PA} _____ [dB(A)]

Case-radiated noise

- L_{PA} _____ [dB(A)]

TVJ, TVJ/.../Easy

TVJ – D – P1 / 600×400 / B1B / E 0 / 200 – 900 / NO								
↓ 1	↓ 2	↓ 3	↓ 4	↓ 5	↓ 6	↓ 7	↓ 8	↓ 9
TVJ – D / 900×300 / Easy								
↓ 1	↓ 2	↓ 4	↓ 5					

1 Type

TVJ VAV terminal unit

2 Acoustic cladding

No entry: none

D With acoustic cladding

3 Material

No entry: galvanised sheet steel

P1 Powder-coated (RAL 7001), silver grey

4 Nominal size [mm]

B × H

5 Attachments (control component)

Example

Easy Easy controller

BC0 Compact controller

B13 Universal controller

6 Operating mode

E Single

M Master

S Slave

F Constant value

A Differential pressure control – extract air

Z Differential pressure control – supply air

7 Signal voltage range

For the actual and setpoint value signals

0 0 – 10 V DC

2 2 – 10 V DC

8 Volume flow rates [m³/h or l/s], differential pressure [Pa]

\dot{V}_{\min} – \dot{V}_{\max} for factory setting

Δp_{\min} for factory setting (operating modes A, Z)

9 Damper blade position

Only with spring return actuators

NO Power off to OPEN

NC Power off to CLOSE

Order example: TVJ/400×200/B13/M0/800–2000 m³/h

Acoustic cladding	Without
Material	Galvanised sheet steel
Nominal size	400 × 200 mm
Attachment	Universal controller
Operating mode	Master
Signal voltage range	0 – 10 V DC
Volume flow rate	800 – 2000 m ³ /h

TVJ with EASYLAB for room control and single operation

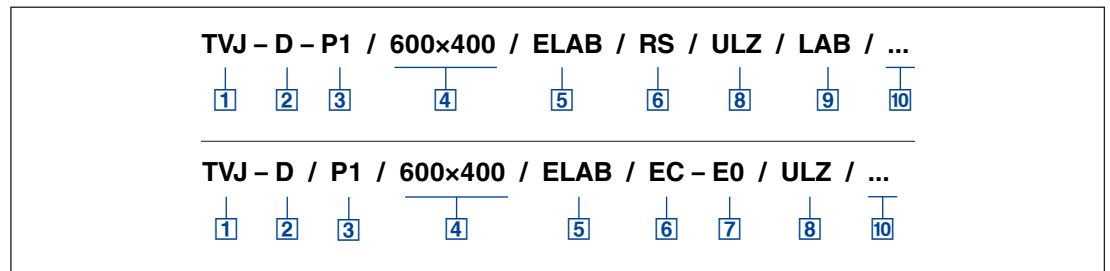

1 Type

TVJ VAV terminal unit

2 Acoustic cladding

No entry: none

D With acoustic cladding

3 Material

No entry: galvanised sheet steel

P1 Powder-coated (RAL 7001), silver grey

4 Nominal size [mm]

B × H

5 Attachments (control component)

ELAB EASYLAB controller TCU3 with fast-running actuator

6 Equipment function

Room control

RS Supply air control (Room Supply)

RE Extract air control (Room Exhaust)

PC Differential pressure control

Single operation

SC Supply air controller

EC Extract air controller

7 External volume flow rate setting

Only for single operation

E0 Voltage signal 0 – 10 V DC

E2 Voltage signal 2 – 10 V DC

2P On-site switch contacts for 2 switching steps

3P On-site switch contacts for 3 switching steps

F Volume flow rate constant value, without signalling

8 Module expansions

Option 1: Power supply

No entry: 24 V AC

T EM-TRF for 230 V AC

U EM-TRF-USV for 230 V AC, provides uninterruptible power supply (UPS)

Option 2: Communication interface

No entry: none

L EM-LON for LonWorks FTT-10A

B EM-BAC-MOD-01 for BACnet MS/TP

M EM-BAC-MOD-01 for Modbus RTU

I EM-IP for BACnet/IP, Modbus/IP and webserver

R EM-IP with real time clock

Option 3: Automatic zero point correction

No entry: none

Z EM-AUTOZERO Solenoid valve for automatic zero point correction

9 Additional functions

Only for room control (equipment function)

Raum management function has been deactivated

LAB Extract air led system (laboratories)

CLR Supply air led system (clean rooms)

Raum management function is active

LAB-RMF Extract air led system (LAB)

CLR-RMF Supply air led system (CLR)

10 Operating values [m³/h or l/s, Pa]

For equipment function 'room control' with additional function RMF

Total room extract air/supply air

\dot{V}_1 : Standard mode

\dot{V}_2 : Reduced operation

\dot{V}_3 : Increased operation

\dot{V}_4 : Constant room supply air

\dot{V}_5 : Constant room extract air

\dot{V}_6 : Supply air/extract air difference

$\Delta p_{\text{setpoint}}$: Setpoint pressure (only with differential pressure control)

For equipment function 'single operation'

E0, E2: $\dot{V}_{\text{min}} / \dot{V}_{\text{max}}$

2P: \dot{V}_1 / \dot{V}_2

3P: $\dot{V}_1 / \dot{V}_2 / \dot{V}_3$

F: \dot{V}_1

Useful additions

Room control panel

BE-LCD-01 40-character display

Order example: TVJ/900x300/ELAB/RS/Z/LAB

Acoustic cladding	Without
Nominal size	900 × 300 mm
Attachments	EASYLAB controller TCU3 with fast-running actuator
Equipment function	Supply air control (Room Supply)
Module expansions	EM-AUTOZERO Solenoid valve for automatic zero point correction
Additional functions	Extract air led system for laboratories

VAV terminal unit, variant TVJ



VAV terminal unit, variant TVJ-D



TVJ

- VAV terminal unit for the control of variable air

volume flow rates

TVJ-D

- VAV terminal unit with acoustic cladding for the control of variable air volume flows
- For rooms where the case-radiated noise of the unit is not sufficiently reduced by a false ceiling
- The rectangular ducts for the room under consideration must have adequate acoustic insulation (provided by others) on the fan and room ends
- Acoustic cladding cannot be retrofitted

TVJ, VARYCONTROL control components

Order code detail	Controlled variable	Controller	Differential pressure transducer	Actuator
Easy controller				
Easy	Volume flow rate	Easy controller TROX	Dynamic, integral	Integral
Compact controller, dynamic				
BC0	Volume flow rate	Compact controller with MP bus interface TROX/Belimo	Dynamic, integral	Integral
BL0		Compact controller with LonWorks interface TROX/Belimo		
BM0		Compact controller with Modbus RTU interface (with connecting cable) TROX/Belimo		
BM0-J6		Compact controller with Modbus RTU interface (with socket)		
XB0		Compact controller TROX/Gruner		
LN0		Compact controller Siemens		
LK0		Compact controller with KNX interface Siemens		
Compact controller, static				
SA0	Volume flow rate	Compact controller with SLC interface Sauter	Static, integral	Integral
SC0				Fast-running actuator, integral
Universal controller, dynamic				
B13	Volume flow rate	Universal controller TROX/Belimo	Dynamic, integral	Actuator
B1B				Spring return actuator
XC3				
Universal controller, static				
BP3	Volume flow rate	Universal controller with MP bus interface TROX/Belimo	Static	Actuator
BPB				Spring return actuator
BPG				Fast-running actuator
BB3		Universal controller TROX/Belimo		Actuator
BBB				Spring return actuator
XD1				Universal controller TROX/Gruner
XD3	Spring return actuator			
BR3	Differential pressure	Universal controller with MP bus interface TROX/Belimo	Static, integral 100 Pa	Actuator
BRB				Spring return actuator
BS3			Static, integral 600 Pa	Actuator
BSB				Spring return actuator
BSG			Fast-running actuator	
BG3			Differential pressure controller TROX/Belimo	Static, integral 100 Pa
BGB		Spring return actuator		
BH3		Static, integral 600 Pa		Actuator
BHB			Spring return actuator	
XE1		Differential pressure controller TROX/Gruner	Static, integral 100 Pa	Actuator
XE3				Spring return actuator
XF1			Static, integral 600 Pa	Actuator
XF3		Spring return actuator		

TVJ, LABCONTROL control components

Order code detail	Controlled variable	Controller	Differential pressure transducer	Actuator
EASYPAB				
ELAB	Room supply air Room extract air Room pressure Single controller	EASYPAB controller TCU3	Static, integral	Fast-running actuator

TVJ

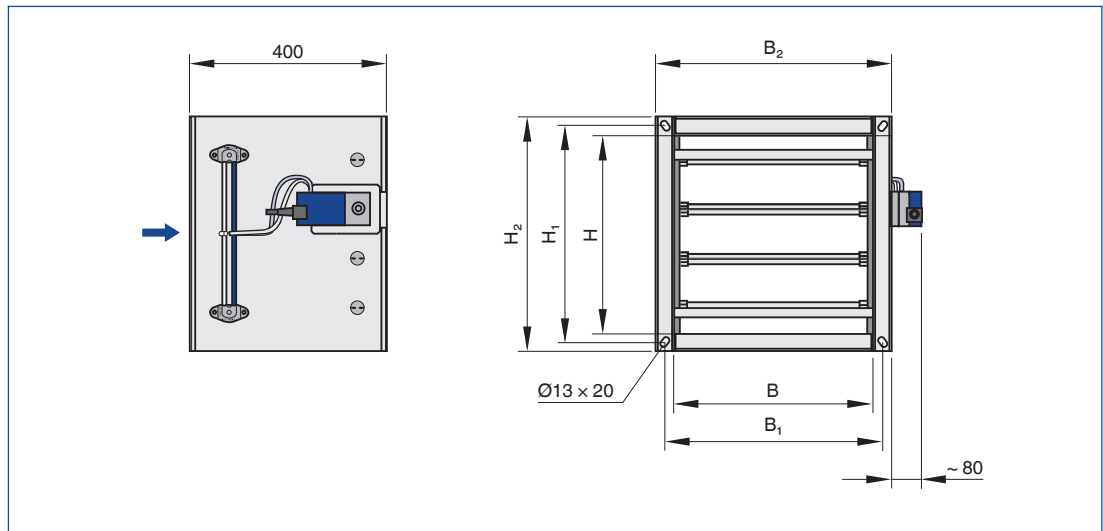

TVJ

Nominal size	B	H	B ₁	B ₂	H ₁	H ₂	m
	mm	mm	mm	mm	mm	mm	kg
200 × 100	200	100	234	276	134	176	6
300 × 100	300	100	334	376	134	176	7
400 × 100	400	100	434	476	134	176	8
500 × 100	500	100	534	576	134	176	9
600 × 100	600	100	634	676	134	176	10
200 × 200	200	200	234	276	234	276	9
300 × 200	300	200	334	376	234	276	10
400 × 200	400	200	434	476	234	276	11
500 × 200	500	200	534	576	234	276	12
600 × 200	600	200	634	676	234	276	13
700 × 200	700	200	734	776	234	276	14
800 × 200	800	200	834	876	234	276	15
300 × 300	300	300	334	376	334	376	10
400 × 300	400	300	434	476	334	376	11
500 × 300	500	300	534	576	334	376	12
600 × 300	600	300	634	676	334	376	13
700 × 300	700	300	734	776	334	376	15
800 × 300	800	300	834	876	334	376	16
900 × 300	900	300	934	976	334	376	18
1000 × 300	1000	300	1034	1076	334	376	19
400 × 400	400	400	434	476	434	476	14
500 × 400	500	400	534	576	434	476	15
600 × 400	600	400	634	676	434	476	16
700 × 400	700	400	734	776	434	476	17
800 × 400	800	400	834	876	434	476	18
900 × 400	900	400	934	976	434	476	21
1000 × 400	1000	400	1034	1076	434	476	20
500 × 500	500	500	534	576	534	576	19
600 × 500	600	500	634	676	534	576	20
700 × 500	700	500	734	776	534	576	22
800 × 500	800	500	834	876	534	576	23
900 × 500	900	500	934	976	534	576	25
1000 × 500	1000	500	1034	1076	534	576	26
600 × 600	600	600	634	676	634	676	19
800 × 600	800	600	834	876	634	676	23
1000 × 600	1000	600	1034	1076	634	676	27
800 × 800	800	800	834	876	834	876	28
1000 × 800	1000	800	1034	1076	834	876	32
1000 × 1000	1000	1000	1034	1076	1034	1076	38

TVJ-D

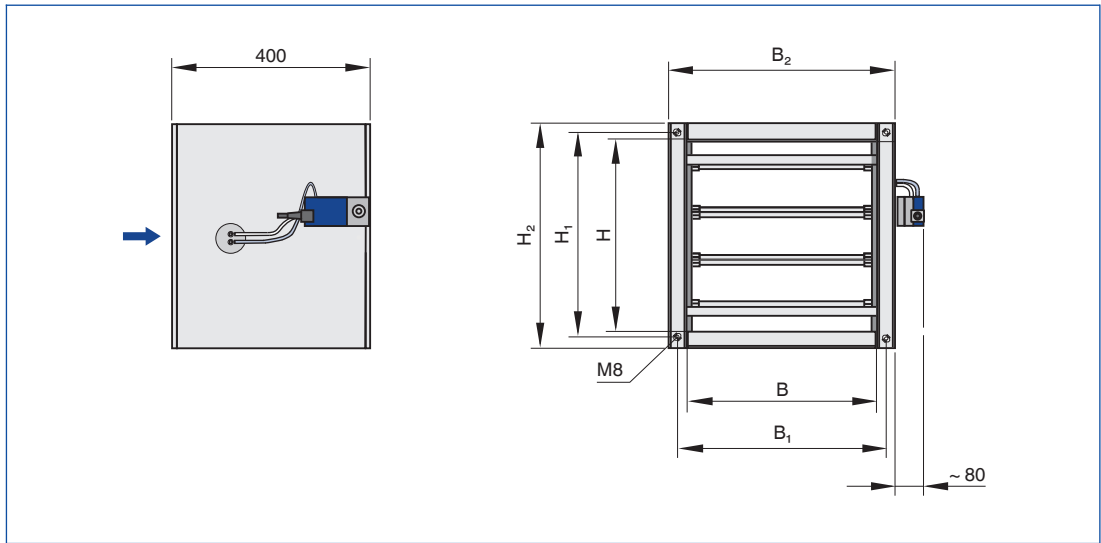

TVJ-D

Nominal size	B	H	B ₁	B ₂	H ₁	H ₂	m
	mm	mm	mm	mm	mm	mm	kg
200 × 100	200	100	234	280	134	180	9
300 × 100	300	100	334	380	134	180	11
400 × 100	400	100	434	480	134	180	12
500 × 100	500	100	534	580	134	180	14
600 × 100	600	100	634	680	134	180	15
200 × 200	200	200	234	280	234	280	14
300 × 200	300	200	334	380	234	280	15
400 × 200	400	200	434	480	234	280	17
500 × 200	500	200	534	580	234	280	18
600 × 200	600	200	634	680	234	280	20
700 × 200	700	200	734	780	234	280	21
800 × 200	800	200	834	880	234	280	23
300 × 300	300	300	334	380	334	380	15
400 × 300	400	300	434	480	334	380	17
500 × 300	500	300	534	580	334	380	18
600 × 300	600	300	634	680	334	380	20
700 × 300	700	300	734	780	334	380	22
800 × 300	800	300	834	880	334	380	24
900 × 300	900	300	934	980	334	380	26
1000 × 300	1000	300	1034	1080	334	380	29
400 × 400	400	400	434	480	434	480	21
500 × 400	500	400	534	580	434	480	23
600 × 400	600	400	634	680	434	480	24
700 × 400	700	400	734	780	434	480	26
800 × 400	800	400	834	880	434	480	27
900 × 400	900	400	934	980	434	480	29
1000 × 400	1000	400	1034	1080	434	480	32
500 × 500	500	500	534	580	534	580	28
600 × 500	600	500	634	680	534	580	30
700 × 500	700	500	734	780	534	580	32
800 × 500	800	500	834	880	534	580	35
900 × 500	900	500	934	980	534	580	37
1000 × 500	1000	500	1034	1080	534	580	39
600 × 600	600	600	634	680	634	680	29
800 × 600	800	600	834	880	634	680	35
1000 × 600	1000	600	1034	1080	634	680	41
800 × 800	800	800	834	880	834	880	42
1000 × 800	1000	800	1034	1080	834	880	48
1000 × 1000	1000	1000	1034	1080	1034	1080	57

Installation and commissioning

- Any installation orientation (except units with static differential pressure transducer)
- With flanges on both ends to make connections to the ducting
- TVJ-D: For constructions with acoustic cladding, ducts on the room side should have cladding up to the acoustic cladding of the controller

Upstream conditions

The volume flow rate accuracy $\Delta\dot{V}$ applies to a straight upstream section of the duct. Bends, junctions or a narrowing or widening of the duct cause turbulence that may affect measurement. Duct connections, e.g. branches off the main duct, must comply with EN 1505. Some installation situations require straight duct sections upstream.

Space required for commissioning and maintenance

Sufficient space must be kept clear near any attachments to allow for commissioning and maintenance. It may be necessary to provide sufficiently sized inspection access openings.

Bend, vertical

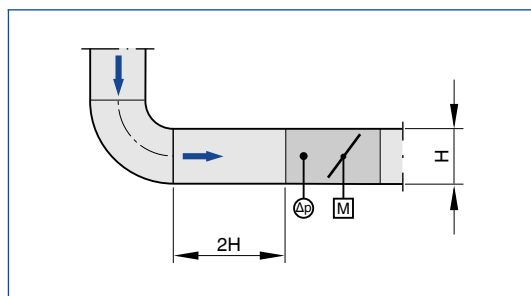

A bend – with a straight duct section of at least 2H upstream of the VAV terminal unit – has only a negligible effect on the volume flow rate accuracy.

Junction, vertical

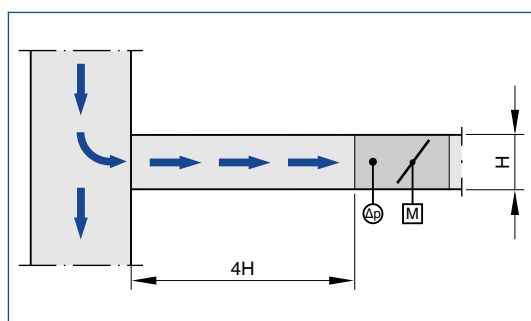

A junction causes strong turbulence. The stated volume flow rate accuracy $\Delta\dot{V}$ can only be achieved with a straight duct section of at least 4H upstream. Shorter upstream sections require a perforated plate in the branch and before the VAV terminal unit. If there is no straight upstream section at all, the control will not be stable, even with a perforated plate.

Bend, horizontal

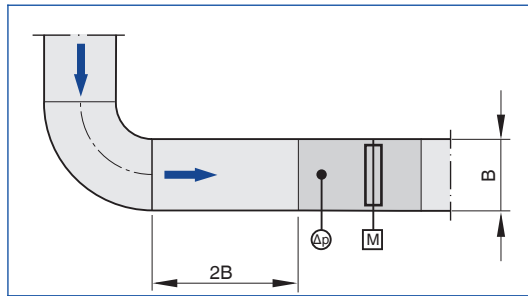

A bend – with a straight duct section of at least 2B upstream of the VAV terminal unit – has only a negligible effect on the volume flow rate accuracy.

Junction, horizontal

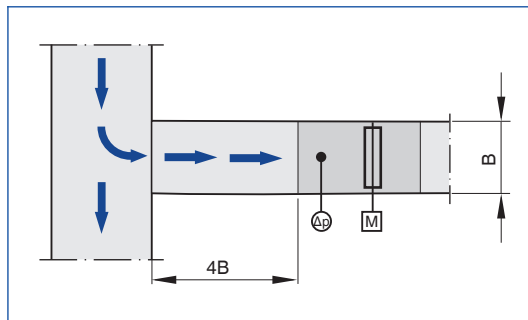

A junction causes strong turbulence. The stated volume flow rate accuracy ΔV can only be achieved with a straight duct section of at least 4B upstream. Shorter upstream sections require a perforated plate in the branch and before the VAV terminal unit. If there is no straight upstream section at all, the control will not be stable, even with a perforated plate.

Access to attachments

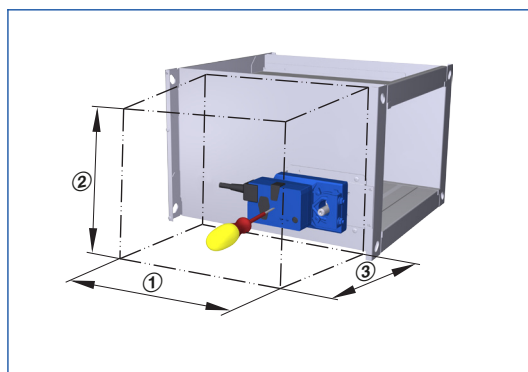

Space required

Attachments	①	②	③
	mm		
VARYCONTROL			
Easy controller	400	H	300
Compact controller	400	H	300
Universal controller	500	H	300
LABCONTROL			
EASYLAB	500	H	400

H: Unit height

Access to battery pack

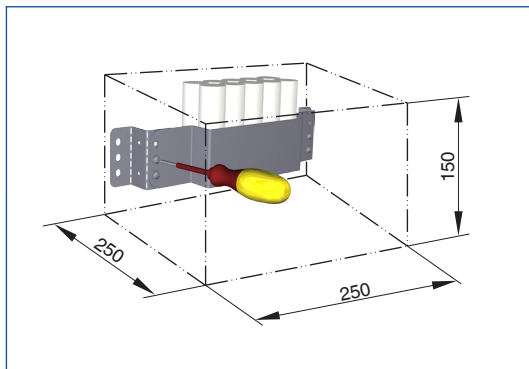

Separate space for fixing and accessing the battery pack (LABCONTROL EASYLAB accessory)

Principal dimensions

ØD [mm]

VAV terminal units made of stainless steel:
Outside diameter of the spigot
VAV terminal units made of plastic: Inside diameter of the connecting spigot

ØD₁ [mm]

Pitch circle diameter of flanges

ØD₂ [mm]

Outside diameter of flanges

ØD₄ [mm]

Inside diameter of the screw holes of flanges

L [mm]

Length of unit including connecting spigot

L₁ [mm]

Length of casing or acoustic cladding

B [mm]

Duct width

B₁ [mm]

Screw hole pitch of flange (horizontal)

B₂ [mm]

Outside dimension of flange (width)

B₃ [mm]

Width of device

H [mm]

Duct height

H₁ [mm]

Screw hole pitch of flange (vertical)

H₂ [mm]

Outside dimension of flange (height)

H₃ [mm]

Unit height

n []

Number of flange screw holes

T [mm]

Flange thickness

m [kg]

Unit weight including the minimum required attachments (e.g. Compact controller)

Acoustic data

f_m [Hz]

Octave band centre frequency

L_{PA} [dB(A)]

A-weighted sound pressure level of air-regenerated noise of the VAV terminal unit, system attenuation taken into account

L_{PA1} [dB(A)]

A-weighted sound pressure level of air-regenerated noise of the VAV terminal unit with secondary silencer, system attenuation taken into account

L_{PA2} [dB(A)]

A-weighted sound pressure level of case-regenerated noise of the VAV terminal unit, system attenuation taken into account

L_{PA3} [dB(A)]

A-weighted sound pressure level of case-regenerated noise of the VAV terminal unit with acoustic cladding, system attenuation taken into account

All sound pressure levels are based on 20 µPa.

Definition of noise

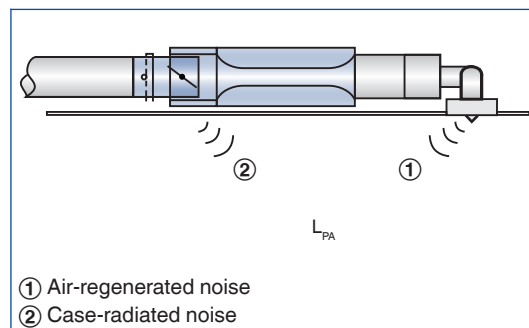

Volume flow rates

\dot{V}_{nom} [m³/h] and [l/s]

Nominal volume flow rate (100 %)

- The value depends on product type and nominal size
- Values are published on the internet and in technical leaflets, and stored in the Easy

- Product Finder design software.
- Reference value for calculating percentages (e.g. \dot{V}_{\max})
- Upper limit of the setting range and maximum volume flow rate setpoint value for the VAV terminal unit

$\dot{V}_{\min \text{ unit}}$ [m³/h] and [l/s]

- Technically possible minimum volume flow rate
- The value depends on product type, nominal size and control component (attachment)
 - Values are stored in the Easy Product Finder design software
 - Lower limit of the setting range and minimum volume flow rate setpoint value for the VAV terminal unit
 - Depending on the controller, setpoint values below $\dot{V}_{\min \text{ unit}}$ (if \dot{V}_{\min} equals zero) may result in unstable control or shut-off

\dot{V}_{\max} [m³/h] and [l/s]

- Upper limit of the operating range for the VAV terminal unit that can be set by customers
- \dot{V}_{\max} can only be smaller than or equal to \dot{V}_{nom}
 - In case of analog signalling to volume flow controllers (which are typically used), the set maximum value (\dot{V}_{\max}) is allocated to the

setpoint signal maximum (10 V) (see characteristic)

\dot{V}_{\min} [m³/h] and [l/s]

- Lower limit of the operating range for the VAV terminal unit that can be set by customers
- \dot{V}_{\min} should be smaller than or equal to \dot{V}_{\max}
 - Do not set \dot{V}_{\min} smaller than $\dot{V}_{\min \text{ unit}}$, otherwise the control may become unstable or the damper blade may close
 - \dot{V}_{\min} may equal zero
 - In case of analog signalling to volume flow controllers (which are typically used), the set minimum value (\dot{V}_{\min}) is allocated to the setpoint signal minimum (0 or 2 V) (see characteristic)

\dot{V} [m³/h] and [l/s]

Volume flow rate

$\Delta\dot{V}$ [± %]

Volume flow rate tolerance from setpoint value

$\Delta\dot{V}_{\text{warm}}$ [± %]

Volume flow rate tolerance for the warm air flow of dual duct terminal units

Differential pressure

Δp_{st} [Pa]

Static differential pressure

$\Delta p_{\text{st min}}$ [Pa]

Static differential pressure, minimum

- The static minimum differential pressure is equal to the pressure loss of the VAV terminal unit when the damper blade is open, caused by flow resistance (sensor tubes, damper mechanism)

- If the pressure on the VAV terminal unit is too low, the setpoint volume flow rate may not be achieved, not even when the damper blade is open
- Important factor in designing the ductwork and in rating the fan including speed control
- Sufficient duct pressure must be ensured for all operating conditions and for all terminal units, and the measurement point or points for speed control must have been selected accordingly to achieve this

Static differential pressure

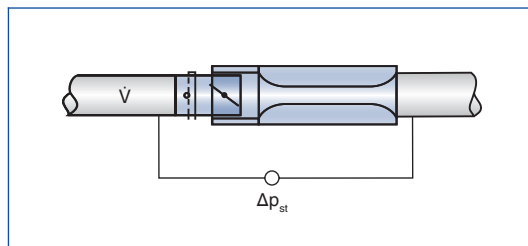

Construction

Galvanised sheet steel

- Casing made of galvanised sheet steel
- Parts in contact with the airflow as described for the product type
- External parts, e.g. mounting brackets or covers, are usually made of galvanised sheet steel

Powder-coated surface (P1)

- Casing made of galvanised sheet steel, powder-coated RAL 7001, silver grey
- Parts in contact with the airflow are powder-coated or made of plastic
- Due to production, some parts that come into contact with the airflow may be stainless steel or aluminium, powder-coated
- External parts, e.g. mounting brackets or

covers, are usually made of galvanised sheet steel

Stainless steel (A2)

- Casing made of stainless steel 1.4201

- Parts in contact with the airflow are powder-coated or made of stainless steel
- External parts, e.g. mounting brackets or covers, are usually made of galvanised sheet