

MAD E L<sup>®</sup>

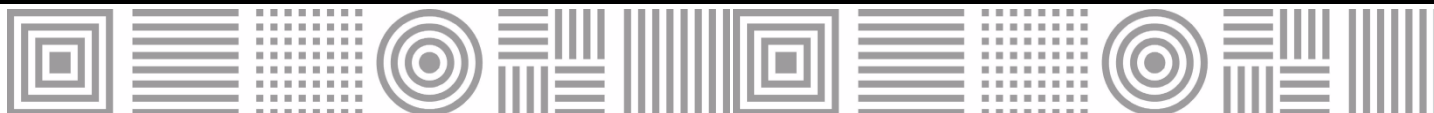

## WAAB 600

### Active chilled beam – width 600



MAD E L<sup>®</sup>

The **WAAB-600** chilled beam is an air/water induction terminal unit that simultaneously provides the supply, thermal treatment and diffusion of supply air, to set internal conditions at the desired comfort levels. Chilled beams take advantage of the excellent thermal properties of water to guarantee optimal comfort levels, with minimal power consumption.

The main heat-transferring component in the **WAAB-600** chilled beam is a battery, formed by copper tubing and aluminium blades. It also incorporates air ducts and a plenum for supplying the ventilation air, which has been pre-treated in a central air conditioning unit. The **WAAB-600** chilled beam can be supplied with connections on the side or on the top, for both supply air and return air.

The unit can be adapted to modular ceilings measuring 600x600, 625x625 and 675x675 for T24 and T15 profiles. Thanks to its reduced size, it can also be installed in low-hanging false ceilings.

### WAAB-600

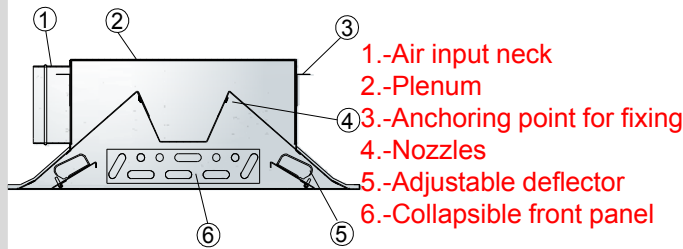

- 1.-Air input neck
- 2.-Plenum
- 3.-Anchoring point for fixing
- 4.-Nozzles
- 5.-Adjustable deflector
- 6.-Collapsible front panel

WAAB-600/.../.../L/...



WAAB-600/.../.../S/...

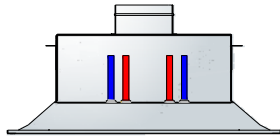

WAAB-600/2T/...



WAAB-600/4T/...

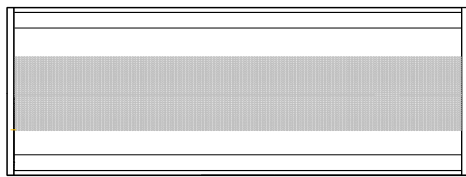
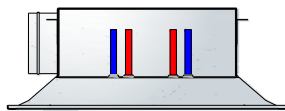

.../FC/



.../FQ/



.../FL/



.../T15/ .../T24/

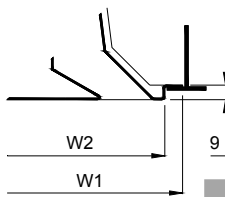

.../ /

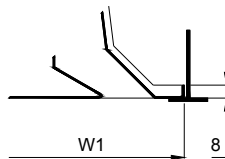

W <sub>N</sub>	/ /		T15		T24	
	W <sub>1</sub>	W <sub>1</sub>	W <sub>2</sub>	W <sub>1</sub>	W <sub>2</sub>	
600	595	595	579	595	571	
625	620	620	604	620	596	
675	670	670	654	670	646	

### CLASSIFICATION

**WAAB-600** Beam for supply air.

.../2T/ 2-tube battery

.../4T/ 4-tube battery.

.../LD/ Right side connection.

.../LI/ Left side connection.

.../S/ Top connection.

.../T15/ Support for dropped panel, 15-mm profile modular ceilings.

.../T24/ Support for dropped panel, 24-mm profile modular ceilings.

.../KS/ Small discharge nozzles.

.../KM/ Medium discharge nozzles.

.../KL/ Large discharge nozzles.

.../FC/ Front panel with circular perforations.

.../FQ/ Front panel with square perforations.

.../FL/ Front panel with lineal aluminium grill.

.../TY/ Type (see pages 5,6 and 7)

### ACCESSORIES

**DEF** Deflecting blades (see page 4)

### MOUNT

**(D)** Angle bracket for suspending from ceiling (see page 8)

### FINISH

**M9016** Lacquered white similar to RAL 9016

**R9010** Lacquered white RAL 9010

**RAL...** Lacquered other colours RAL

### MATERIAL

Galvanised steel body, ABS plastic deflective blades and battery with copper tubing and aluminium blades.

The tubes connected to the battery have a diameter of 12 mm and a thickness of 1mm, in fulfilment of the EN 1057:1996 European Standard. The battery's maximum working pressure is 1 MPa.

### SPECIFICATION TEXT

Supply and installation of active chilled beam for supply air and return air, with 4-tube battery, right side connection plenum, pre-set medium nozzles, circular perforated front panel, type **LDR1**, with deflective blades, **WAAB-600 / 4T / LD / KM / FC / LDR1 1195x900 /+ DEF**. Built in lacquered white galvanised steel **R9010**. Brand **MADEL**.

The ventilation air is injected through nozzles that cause the air to accelerate and force air induction in the room, through the battery. Subsequently, the two masses of air (the induced air and ventilation air) are supplied to the space that requires air-conditioning.

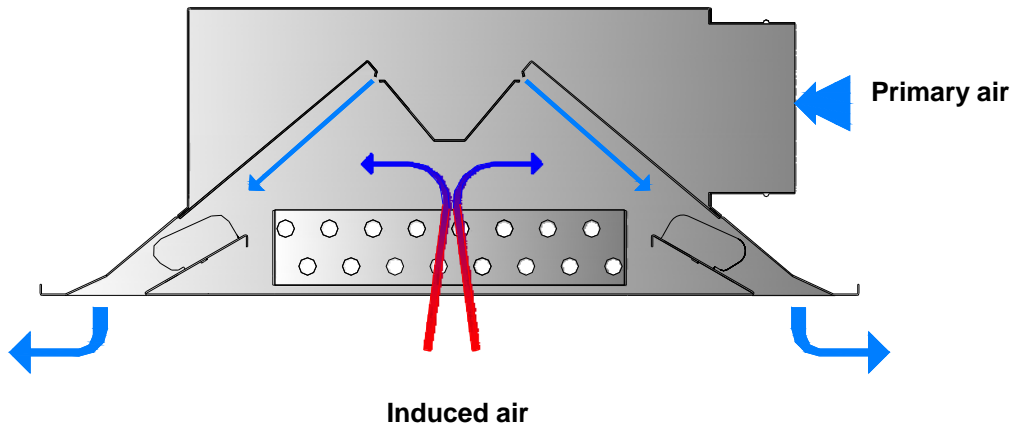

The **WAAB 600** has been designed so that it can be accessed easily for maintenance and servicing operations. For this, it has 4 fastening hinges, which keep the internal frame in position. Thus, the internal frame is collapsible over two axes, by simply moving the two hinges situated on the same face as the internal frame. In this way, both the battery and the primary airflow regulating systems are easily accessible for any necessary maintenance and adjustment operations. Plus, once the internal frame has been collapsed over one of its axes, the internal frame can be completely removed by moving the two remaining hinges.

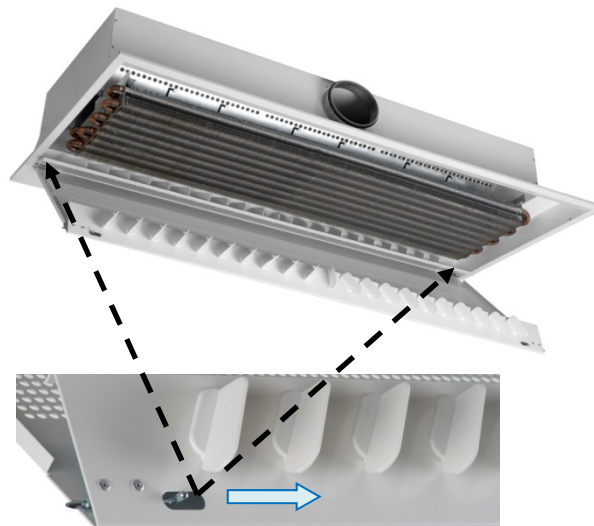

Once the internal frame of the **WAAB 600** chilled beam has been released, the airflow can be adjusted and the deflection angle changed.

**Airflow adjustment**

The **WAAB 600** chilled beam can be supplied with a primary airflow adjustment system. This adjustment can be made using a tube wrench with a diameter of 8 mm, making it easy to select between three air output configurations. Thus, even if the project specifications change, the primary airflow can still be readjusted using the same installation.

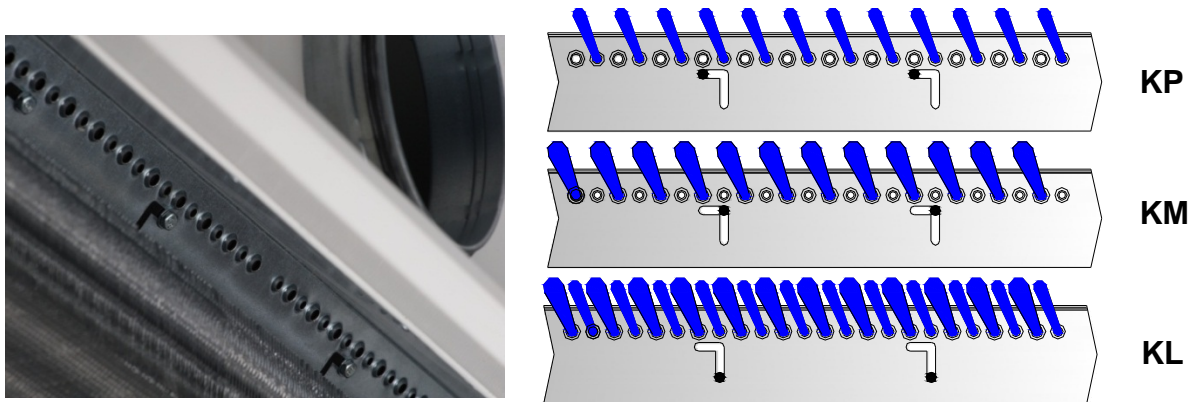

**Modification of the air deflection angle.**

The **WAAB 600** chilled beam can be supplied with air deflectors situated over the internal frame. The deflectors can be adjusted individually over a range of 0 to 45 °, permitting a wide variety of different air diffusion configurations in the treated area.

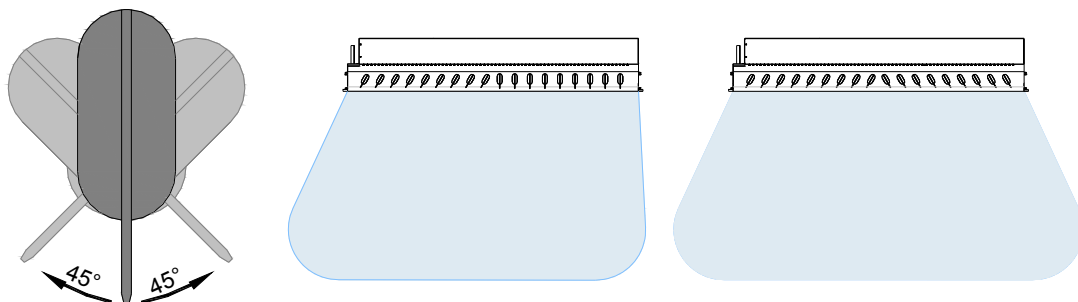



TYPES AND DIMENSIONS

WAAB 600

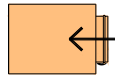
 Circular side supply air connection.

 Circular side return air connection

 Cold water connection.  
 Hot water connection.

 Circular top supply air connection

 Circular top return air connection.

Left side.

Right side.

Top.

LI

LD

S

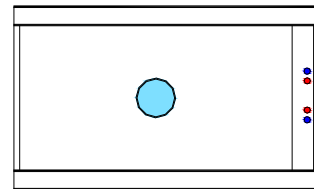
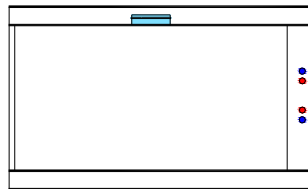
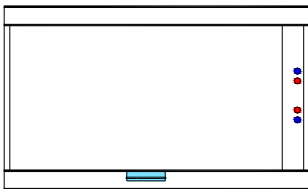

LIR1

LDR1

SR1

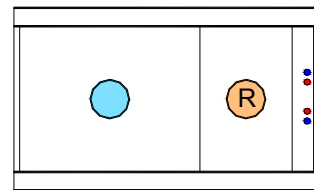
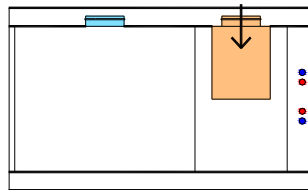
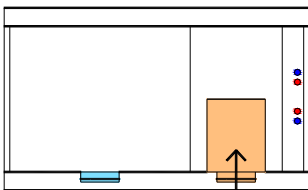

LIR2

LDR2

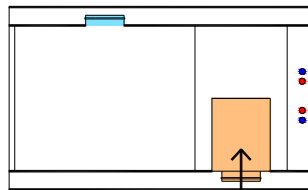
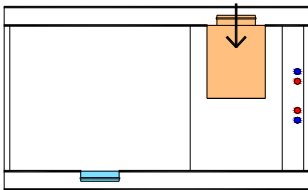

The typological definition should indicate the type of configuration, followed by the nominal length ( $L_N$ ) and the total length ( $L_1$ ).

E.g : LIR1  $L_1 \times L_N$  mm

$L_1 = 895 \dots 2995$  mm

$L_N$  may only be supplied in standard lengths

**TYPES AND DIMENSIONS**

**WAAB 600**

LI, LD, S  
LN = 900, 1200, 1500, 1800

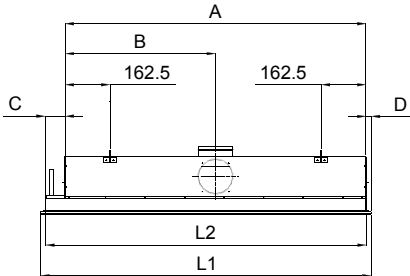

LIR1, LIR2, LDR1, LDR2 SR1  
LN = 900, 1200, 1500, 1800

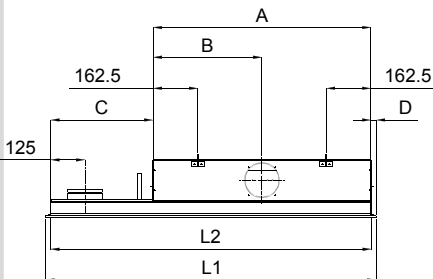

LI, LD, S  
LN = 1800, 2100, 2400

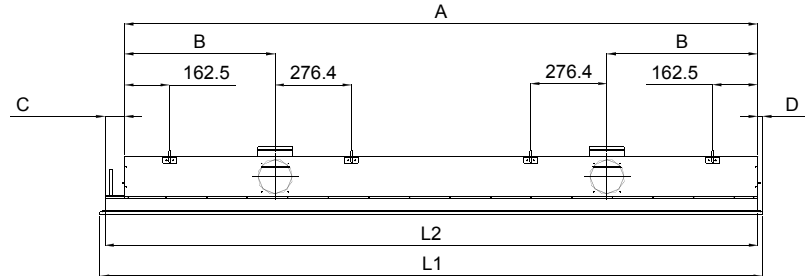

LIR1, LIR2, LDR1, LDR2, SR1  
LN = 1800, 2100, 2400

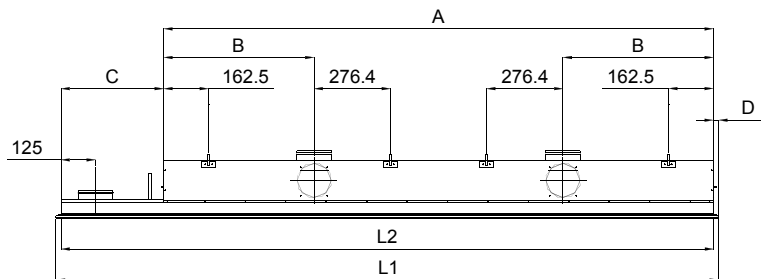

Configuration with side air connection

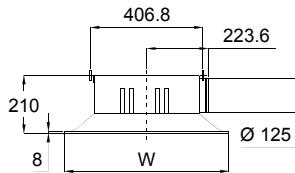

Configuration with upper air connection

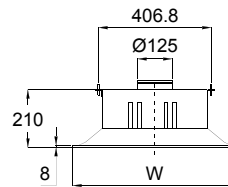

**1.- WAAB 600 - LI, LD, S**

LI, LD, S											
L <sub>1</sub> (mm)		L <sub>N</sub> (mm)	W (mm)	L <sub>2</sub> (mm)		A (mm)	B (mm)	D (mm)	C (mm)		φ (mm)
min	max			min	max				min	max	
895	2995	<b>900</b>	<b>595</b>	860	2960	788	394,0	18,5	71	2171	1-125
1195	2995	<b>1200</b>	<b>595</b>	1160	2960	1088	544,0	18,5	71	1871	1-125
1495	2995	<b>1500</b>	<b>595</b>	1460	2960	1388	694,0	18,5	71	1571	1-125
1795	2995	<b>1800</b>	<b>595</b>	1760	2960	1688	844,0	18,5	71	1271	1-125
2095	2995	<b>2100</b>	<b>595</b>	2060	2960	1988	450	18,5	71	971	2-125
2395	2995	<b>2400</b>	<b>595</b>	2360	2960	2288	600	18,5	71	671	2-125
2695	2995	<b>2700</b>	<b>595</b>	2660	2960	2588	750	18,5	71	371	2-125
2995	2995	<b>3000</b>	<b>595</b>	2960	2960	2888	900	18,5	71	71	2-125

**2.- WAAB 600 – LIR, LDR**

<i>LIR1 , LIR2 , LDR1 , LDR2, SR1</i>											
<i>L<sub>1</sub> (mm)</i>		<i>L<sub>N</sub> (mm)</i>	<i>W (mm)</i>	<i>L<sub>2</sub> (mm)</i>		<i>A (mm)</i>	<i>B (mm)</i>	<i>D (mm)</i>	<i>C (mm)</i>		<i>φ (mm)</i>
<i>min</i>	<i>max</i>			<i>min</i>	<i>max</i>				<i>min</i>	<i>max</i>	
1195	2995	<b>900</b>	<b>595</b>	1160	2960	788	394,0	18,5	371	2171	1-125
1495	2995	<b>1200</b>	<b>595</b>	1460	2960	1088	544,0	18,5	371	1871	1-125
1795	2995	<b>1500</b>	<b>595</b>	1760	2960	1388	694,0	18,5	371	1571	1-125
2095	2995	<b>1800</b>	<b>595</b>	2060	2960	1688	844,0	18,5	371	1271	1-125
2395	2995	<b>2100</b>	<b>595</b>	2360	2960	1988	450	18,5	371	971	2-125
2695	2995	<b>2400</b>	<b>595</b>	2660	2960	2288	600	18,5	371	671	2-125
2995	2995	<b>2700</b>	<b>595</b>	2960	2960	2588	750	18,5	371	371	2-125

**3.- WAAB 625 - LI, LD, S**

<i>LI , LD, S</i>											
<i>L<sub>1</sub> (mm)</i>		<i>L<sub>N</sub> (mm)</i>	<i>W (mm)</i>	<i>L<sub>2</sub> (mm)</i>		<i>A (mm)</i>	<i>B (mm)</i>	<i>D (mm)</i>	<i>C (mm)</i>		<i>φ (mm)</i>
<i>min</i>	<i>max</i>			<i>min</i>	<i>max</i>				<i>min</i>	<i>max</i>	
932	2807	<b>937</b>	<b>620</b>	872	2747	788	394,0	31,0	83,0	1958,0	1-125
1245	2807	<b>1250</b>	<b>620</b>	1185	2747	1088	544,0	31,0	96,0	1658,0	1-125
1557	2807	<b>1562</b>	<b>620</b>	1497	2747	1388	694,0	31,0	108,0	1358,0	1-125
1870	2807	<b>1875</b>	<b>620</b>	1810	2747	1688	844,0	31,0	121,0	1058,0	1-125
2182	2807	<b>2187</b>	<b>620</b>	2122	2747	1988	450	31,0	133,0	758,0	2-125
2495	2807	<b>2500</b>	<b>620</b>	2435	2747	2288	600	31,0	146,0	458,0	2-125
2807	2807	<b>2700</b>	<b>620</b>	2747	2747	2588	750	32,0	158,0	158,0	2-125

**4.- WAAB 625 – LIR, LDR**

<i>LIR1 , LIR2 , LDR1 , LDR2, SR1</i>											
<i>L<sub>1</sub> (mm)</i>		<i>L<sub>N</sub> (mm)</i>	<i>W (mm)</i>	<i>L<sub>2</sub> (mm)</i>		<i>A (mm)</i>	<i>B (mm)</i>	<i>D (mm)</i>	<i>C (mm)</i>		<i>φ (mm)</i>
<i>min</i>	<i>max</i>			<i>min</i>	<i>max</i>				<i>min</i>	<i>max</i>	
1245	2807	<b>937</b>	<b>620</b>	1185	2747	788	394,0	31,0	396,0	1958,0	1-125
1557	2807	<b>1250</b>	<b>620</b>	1497	2747	1088	544,0	31,0	408,0	1658,0	1-125
1870	2807	<b>1562</b>	<b>620</b>	1810	2747	1388	694,0	31,0	421,0	1358,0	1-125
2182	2807	<b>1875</b>	<b>620</b>	2122	2747	1688	844,0	31,0	433,0	1058,0	1-125
2495	2807	<b>2187</b>	<b>620</b>	2435	2747	1988	450	31,0	446,0	758,0	2-125
2807	2807	<b>2500</b>	<b>620</b>	2747	2747	2288	600	32,0	458,0	458,0	2-125

**5.- WAAB 675 - LI, LD, S**

<i>LI , LD, S</i>											
<i>L<sub>1</sub> (mm)</i>		<i>L<sub>N</sub> (mm)</i>	<i>W (mm)</i>	<i>L<sub>2</sub> (mm)</i>		<i>A (mm)</i>	<i>B (mm)</i>	<i>D (mm)</i>	<i>C (mm)</i>		<i>φ (mm)</i>
<i>min</i>	<i>max</i>			<i>min</i>	<i>max</i>				<i>min</i>	<i>max</i>	
1007	2695	<b>1012</b>	<b>670</b>	897	2585	788	394,0	56,0	108,0	1796,0	1-125
1345	2695	<b>1350</b>	<b>670</b>	1235	2585	1088	544,0	56,0	146,0	1496,0	1-125
1682	2695	<b>1687</b>	<b>670</b>	1572	2585	1388	694,0	56,0	183,0	1196,0	1-125
2020	2695	<b>2025</b>	<b>670</b>	1910	2585	1688	844,0	56,0	221,0	896,0	1-125
2357	2695	<b>2362</b>	<b>670</b>	2247	2585	1988	450	56,0	258,0	596,0	2-125
2695	2695	<b>2700</b>	<b>670</b>	2585	2585	2288	600	56,0	296,0	296,0	2-125

**6.- WAAB 675 – LIR, LDR**

<i>LIR1 , LIR2 , LDR1 , LDR2, SR1</i>											
<i>L<sub>1</sub> (mm)</i>		<i>L<sub>N</sub> (mm)</i>	<i>W (mm)</i>	<i>L<sub>2</sub> (mm)</i>		<i>A (mm)</i>	<i>B (mm)</i>	<i>D (mm)</i>	<i>C (mm)</i>		<i>φ (mm)</i>
<i>min</i>	<i>max</i>			<i>min</i>	<i>max</i>				<i>min</i>	<i>max</i>	
1345	2695	<b>1012</b>	<b>670</b>	1235	2585	788	394,0	56,0	446,0	1796,0	1-125
1682	2695	<b>1350</b>	<b>670</b>	1572	2585	1088	544,0	56,0	483,0	1496,0	1-125
2020	2695	<b>1687</b>	<b>670</b>	1910	2585	1388	694,0	56,0	521,0	1196,0	1-125
2357	2695	<b>2025</b>	<b>670</b>	2247	2585	1688	844,0	56,0	558,0	896,0	1-125
2695	2695	<b>2362</b>	<b>670</b>	2585	2585	1988	450	56,0	596,0	596,0	2-125

The **WAAB 600** chilled beam incorporates a series of mounting angle brackets on both sides. These brackets have an 18-mm long slot, so that the chilled beam can be easily mounted in the installation. The number of brackets available varies depending on the nominal length of the selected chilled beam; 4 for  $L_N \leq 1800$  mm and 8 for  $L_N \geq 2100$  mm. The unit should be suspended from the structure with officially approved steel supports, cables or rods. Once suspended, the primary air duct should be connected to the plenum's neck. Likewise, the battery should be connected with solid elements, welding or quick connect fittings. Check that the hydraulic circuit has been properly emptied and that the beam is properly connected to the ventilation system to prevent air leaks.

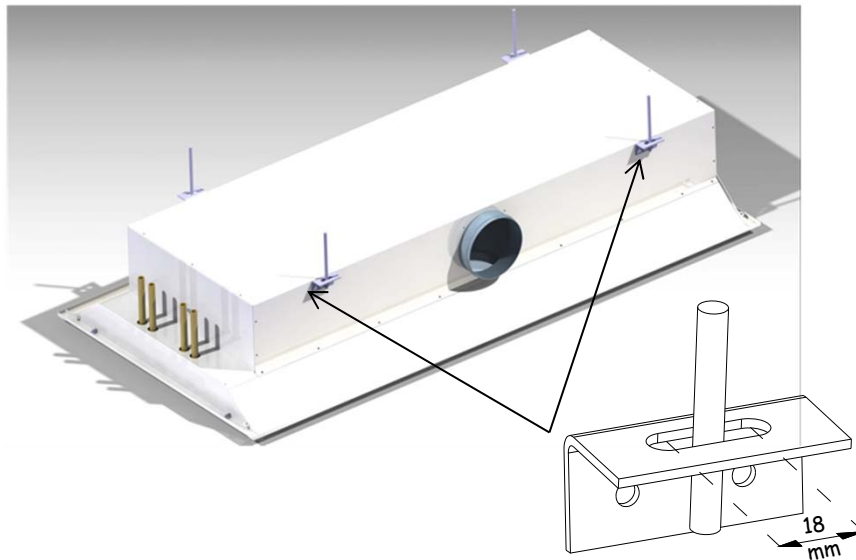

WAAB-.../ /

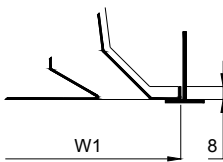

$W_N$	/ /	T15		T24	
	$W_1$	$W_1$	$W_2$	$W_1$	$W_2$
600	595	595	579	595	571
625	620	620	604	620	596
675	670	670	654	670	646

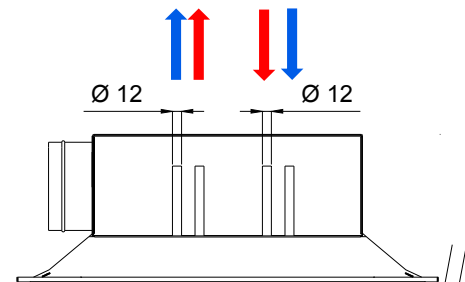

WAAB-.../ T15 /

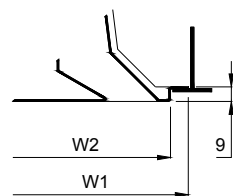

WAAB-.../ T24 /

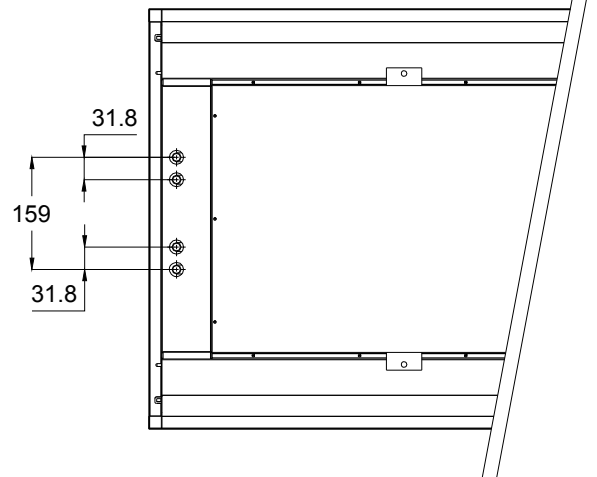
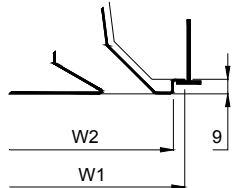



**DEFINITIONS**

**WAAB 600**

Determining the performance/characteristics of chilled beams properly requires the performance of both thermal and diffusion tests, based on the benchmarks of standards EN 15116, EN 13182 and EN 14240.

For technical product selection uses software selection MADEL:

<http://www.madel.com/en/downloads-en/>

The benchmark is as follows :

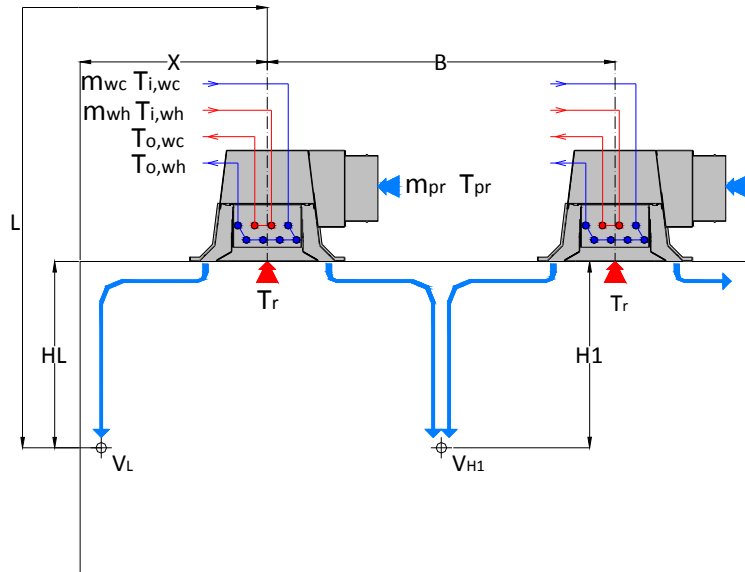
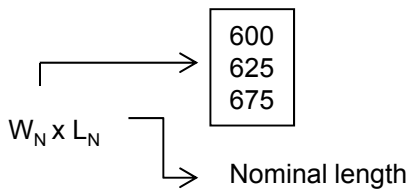

$V_{H1}$	(m/s)	Air speed at $H_1$ height
$V_L$	(m/s)	Air speed at $L$ height
$H_1$	(m)	Distance from ceiling to living area (1.8 m)
$B$	(m)	Distance between two chilled beams
$L_N$	(m)	Nominal length of chilled beam
$L_{WA}$	(dBA)	Sound power level
$P$	(W)	Total power ( $P=P_{pr} + P_{w,r}$ )
$P_{pr}$	(W)	Primary airflow rate
$P_w$	(W)	Nominal water cooling or heating power
$P_{w,r}$	(W)	Water cooling or heating power
$m_{pr}$	( $m^3/h$ )	Primary airflow volume
$m_{wh}$	(l/h)	Hot water flow volume
$m_{wc}$	(l/h)	Cold water flow volume
$T_{pr}$	( $^{\circ}C$ )	Primary air temperature
$T_R$	( $^{\circ}C$ )	Premises benchmark temperature
$T_{i,wc}$	( $^{\circ}C$ )	Cold water temperature at battery input
$T_{o,wc}$	( $^{\circ}C$ )	Cold water temperature at battery output
$T_{i,wh}$	( $^{\circ}C$ )	Hot water temperature at battery input
$T_{o,wh}$	( $^{\circ}C$ )	Hot water temperature at battery output
$P_a$	(Pa)	Static pressure inside plenum
$\Delta P_w$	(kPa)	Pressure drop in water circuit
$\Delta t_{aw}$	( $^{\circ}C$ )	Difference in premises benchmark temperature and supply water temperature ( $\Delta t_{aw}= T_R - T_{i,w}$ )
$\Delta t_{pr}$	( $^{\circ}C$ )	Difference in premises benchmark temperature and primary supply air temp. ( $\Delta t_{pr}= T_R - T_{pr}$ )
$F_w$		Correction factor of water rate based on water flow volume ( $P_{w,r}=P_w * F_w$ )
$\Delta t_w$	( $^{\circ}C$ )	$C^{\circ}$ Thermal gradient in battery

The nominal working conditions for WAAB 600 chilled beams are as follows :

Cooling 2 and 4 tubes		Heating 2 tubes		Heating 4 tubes	
$T_R=$	26 $^{\circ}C$	$T_R=$	22 $^{\circ}C$	$T_R=$	22 $^{\circ}C$
$m_{wc}=$	110 l/h ( $L_N$ 900 a 1800) <sup>(1)</sup>	$m_{wh}=$	110 l/h ( $L_N$ 900 a 1800)	$m_{wh}=$	50 l/h ( $L_N$ 900 a 1800)
$m_{wc}=$	220 l/h ( $L_N$ 1800 a 2700) <sup>(1)</sup>	$m_{wh}=$	220 l/h ( $L_N$ 1800 a 2700)	$m_{wh}=$	110 l/h ( $L_N$ 1800 a 2700)
$T_{i,wc}=$	16 $^{\circ}C$ <sup>(2)</sup>	$T_{i,wh}=$	40 $^{\circ}C$ <sup>(3)</sup>	$T_{i,wh}=$	40 $^{\circ}C$ <sup>(3)</sup>
$T_{pr}=$	16 $^{\circ}C$	$T_{pr}=$	22 $^{\circ}C$	$T_{pr}=$	22 $^{\circ}C$

(1) The recommended flow volume will maintain a thermal gradient of 3-4  $^{\circ}C$  in the battery.

(2) We recommend using a supply water temperature of 14-16  $^{\circ}C$  to avoid condensation.

(3) We recommend using a supply water temperature of 35-40  $^{\circ}C$  to avoid air stratification.