

MADEL®



WAAB SUITE 1-way Active Chilled Beam



MADEL®

The **WAAB SUITE** chilled beam is an air-water induction terminal unit that simultaneously allows the supply, heat treatment and diffusion of supply air, in order to maintain indoor conditions at the desired level of comfort. The chilled beams take advantage of water's excellent thermal properties guarantee an optimum level of comfort with minimum energy consumption.

The main heat-transferring component in the **WAAB SUITE** chilled beam is a battery consisting of copper pipes and aluminium fins. It also incorporates air connections and a plenum to provide ventilation air, which has been pre-treated in a central air conditioning unit. The **WAAB SUITE** chilled beam is only supplied with a side connection.

It is specially designed to be installed in false ceilings, treating the air through the battery, collected in the lower part of the beam, and supplied horizontally through the linear grilles. Its configuration makes it particularly suitable for corridors of hotel and hospital rooms. It is available in widths 900 and 1200.

WAAB SUITE

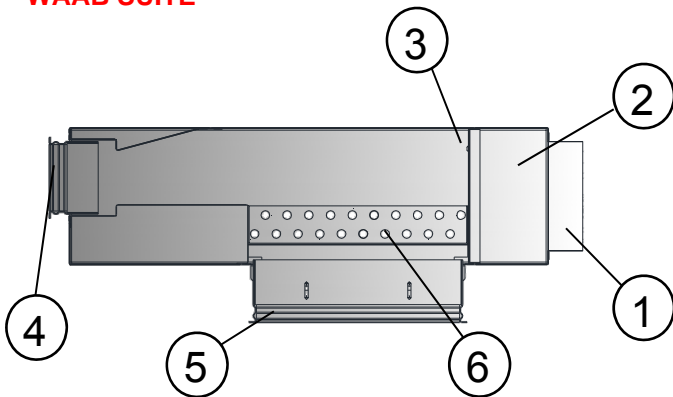

- 1.- Primary air inlet
- 2.- Plenum
- 3.- Nozzles
- 4.- Removable linear supply grille (S)
- 5.- Removable linear induction grille (O)
- 6.- Battery

WAAB SUITE /2T/LD/...



WAAB SUITE /4T/LI/...



RATING

WAAB SUITE Beam for air supply.

- ../2T/ Two-pipe battery.
- ../4T/ Four-pipe battery.
- ../LD/ Right side connection.
- ../LI/ Left side connection.
- ../KS/ Small supply nozzles.
- ../KM/ Medium supply nozzles.
- ../KL/ Large supply nozzles.
- ../AMT/ AMT single deflection grille
- ../LMT/ LMT linear grille
- ../LMT-15/ LMT-15 linear grille
- ../L_N/ Nominal length (900 and 1200).

FIXING

(D) Slots on the plenum for securing to ceiling (see page 5).

FINISHES

- M9016** White lacquered similar to RAL 9016
- R9010** White lacquered RAL 9010
- RAL...** Lacquered in other colours RAL
- AA...** Anodized

MATERIAL

Galvanized steel body, battery with copper pipes and aluminium fins.

The battery's connection pipes have a diameter of 12 mm and a thickness of 1 mm, complying with the European Standard EN 1057:1996. The battery's maximum working pressure is 1 MPa.

PRESCRIPTION TEXT

Supply and installation of active chilled beam for supply and return, with 4-pipe battery, plenum with right side connection, prefixed medium nozzles **WAAB SUITE / 4T / LD / KM / LMT / 1200** built with matt silver anodized aluminium fins **AA**. MADEL make.

CONSTRUCTION AND OPERATING SYSTEM

WAAB SUITE

The ventilation air is injected through nozzles that accelerate it, inducing and forcing the induction of air from the room through the battery. Subsequently, the mixture of the two air masses, the induced air and the ventilation air, is supplied to the space to be air conditioned.

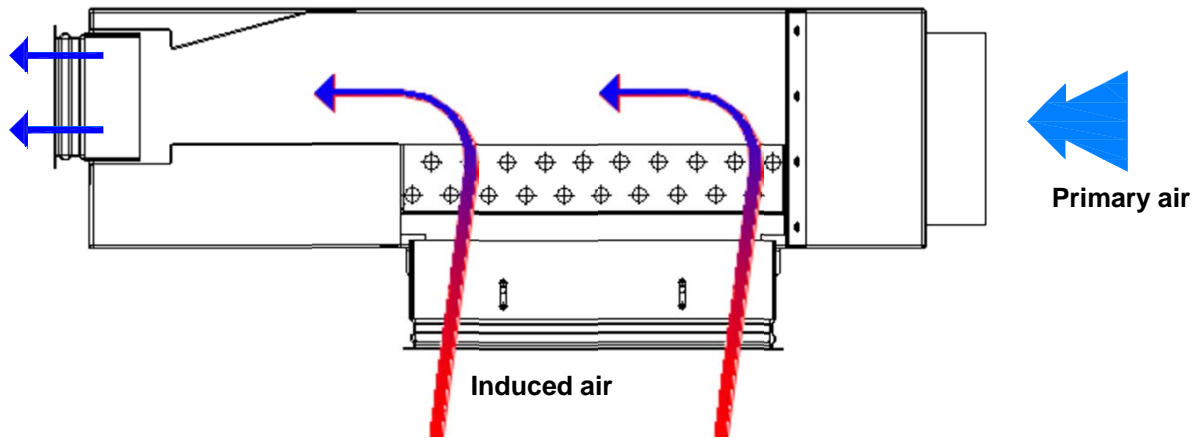

WAAB SUITE has been designed to be easily accessible for maintenance and service operations. For these operations it has 4 clips, which hold the return air frame in place. The supply air frame can be removed or repositioned by moving it horizontally. In the case of the induced air frame, the movement is vertical.

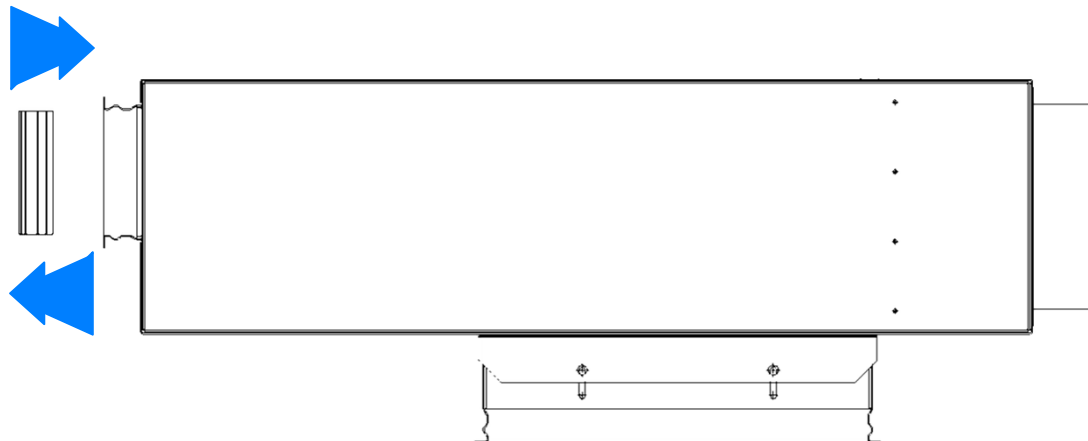

Once the **WAAB SUITE** chilled beam return air frame has been released, you can adjust the supply nozzles and access the top of the battery. Removal of the induced air frame provides access to the lower part of the battery.

Removal is not necessary to modify the orientation of the grille slats.

Adjusting the air flow

The **WAAB SUITE** chilled beam can be supplied with a primary air flow adjustment system. This adjustment is carried out with a Phillips screwdriver, and enables the simple selection between three outgoing air configurations. This way, if there is a change in the project specifications, the primary air flow can be readjusted in the actual installation.

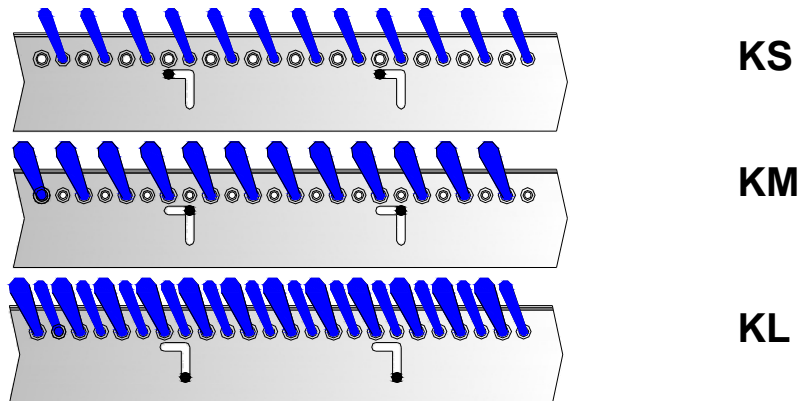

Modification of the air deflection angle.

The **WAAB SUITE** chilled beam can be supplied with the linear grilles with AMT adjustable slats or with LMT fixed slats at 0° or 15° that allow the air direction to be deflected.

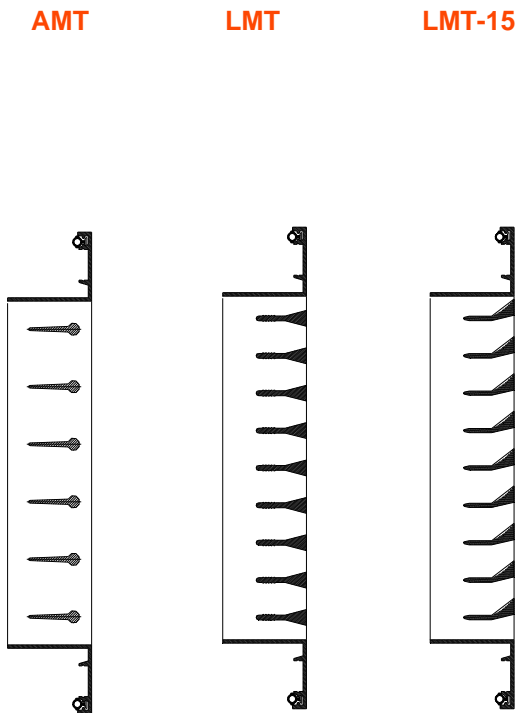

WAAB SUITE Beam for air supply.

GRILLES

- AMT** Aluminium linear grille with adjustable slats
- LMT** Aluminium linear grille with fixed slats
- LMT-15** Aluminium linear grille with fixed slats at 15°

FIXING SYSTEM

- (S)** Clips for supply
- (O)** Hidden for return

AMT FINISHES

- AA** Matt silver anodized.
- M9016** White lacquered similar to RAL 9016.
- R9010** White lacquered RAL 9010.

LMT FINISHES

- AA** Matt silver anodized.
- M9016** White lacquered similar to RAL 9016.
- R9010** White lacquered RAL 9010.
- RAL...** Lacquered in other colours RAL.

Right connection

Left connection

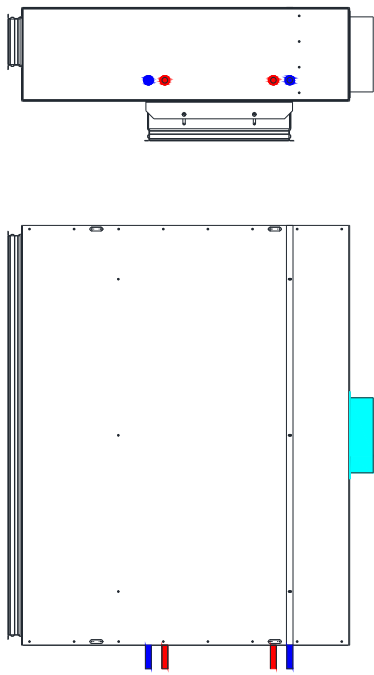
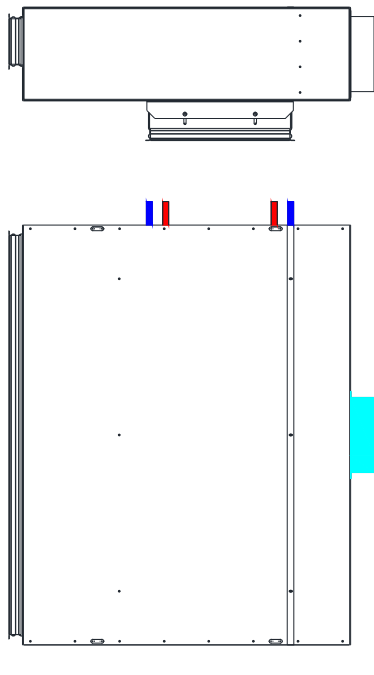

- Cold water connection
- Hot water connection
- Side connection

The **WAAB SUITE** chilled beam incorporates four fixing slots on the plenum. These slots are 20 mm long, facilitating the assembly of the cold beam in the installation. The unit will be suspended from the slab using approved rods, cables or metallic supports. Once suspended, the primary air duct must be connected to the neck of the plenum. In addition, the battery will be connected using rigid elements, welding or through quick fixing connectors. It will be important to ensure good air emptying from the hydraulic circuit, as well as a good connection of the ventilation system to prevent air leaks.

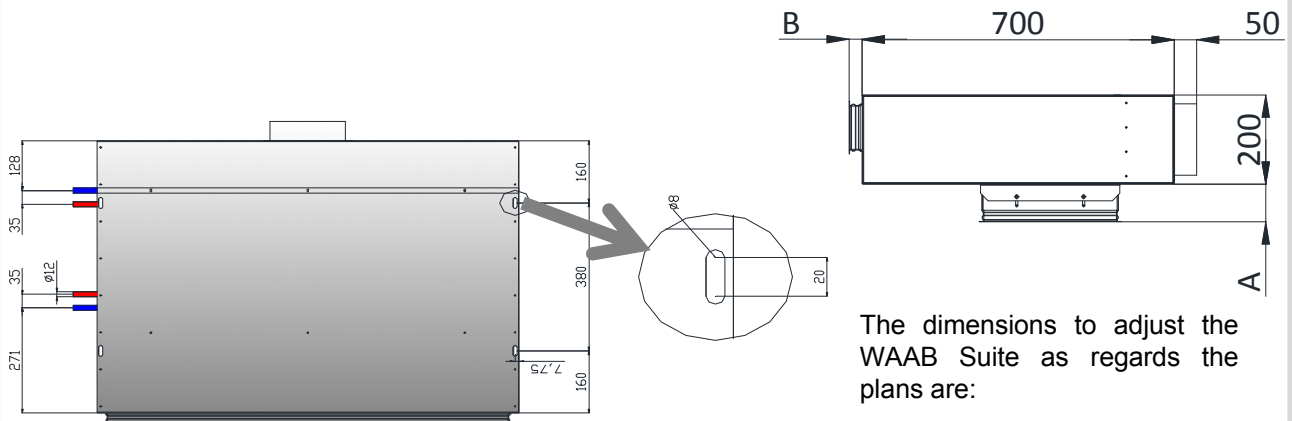

The dimensions to adjust the WAAB Suite as regards the plans are:

- A 85 to 105 mm
- B 9 to 29 mm

DEFINITIONS

WAAB SUITE

The characterization of the chilled beams requires both thermal and diffusion testing taking as a reference standards EN 15116, EN 13182 and EN 14240.

Below are the characteristic curves of each of the models corresponding to the WAAB SUITE product. The referencing method will be:

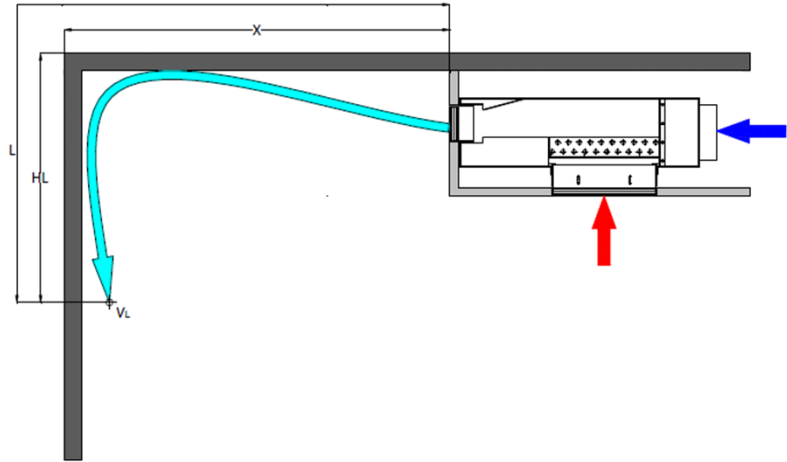

V_L	(m/s)	Air speed at height L
H	(m)	Distance from ceiling to living area (1.8 m)
L_N	(m)	Nominal length of chilled beam
L_{WA}	(dBA)	Sound power level
P	(W)	Total power ($P=P_{dr}+P_{w,r}$)
P_{dr}	(W)	Primary air-flow rate
P_w	(W)	Nominal water cooling or heating output
$P_{w,r}$	(W)	Water cooling or heating output
m_{dr}	(m^3/h)	Primary air flow
m_{wh}	(l/h)	Hot water flow
m_{wc}	(l/h)	Cold water flow
T_{dr}	(°C)	Primary air temperature
T_R	(°C)	Reference temperature of the premises
$T_{i,wc}$	(°C)	Battery incoming cold water temperature
$T_{o,wc}$	(°C)	Battery outgoing cold water temperature
$T_{i,wh}$	(°C)	Battery incoming hot water temperature
$T_{o,wh}$	(°C)	Battery outgoing hot water temperature
P_a	(Pa)	Static pressure inside plenum
ΔP_w	(kPa)	Load loss in water circuit
Δt_{aw}	(°C)	Difference in reference temperature of premises and water supply ($\Delta t_{aw} \leq T_R - T_{i,w}$)
Δt_{pr}	(°C)	Difference in reference temperature of premises and primary air supply ($\Delta t_{pr} = T_R - T_{dr}$)
F_w		Correction factor of water flow rate according to water flow ($P_{w,r} = P_w \cdot F_w$)
Δt_w	(°C)	Shighthermal in the battery (°C)

The nominal working conditions of WAAB SUITE chilled beams are as follows:

Cooling 2 and 4 Pipes		Heating 2T		Heating 4 Pipes	
RT	26 °C	RT	22 °C	RT	22 °C
mwc	110 l/h	mwc	110 l/h	mwc	110 l/h
$T_{i,wc}$	16 °C	$T_{i,wc}$	35-40 °C	$T_{i,wc}$	35-40 °C
T_{pr}	16 °C	T_{pr}	22 °C	T_{pr}	22 °C

(1) The recommended flow maintains a thermal gap of 2-4 °C in the battery.
 (2) It is recommended to use a water flow temperature between 14-16 °C to avoid condensation.
 (3) It is recommended to use a water flow temperature between 35-40 °C to avoid air stratification.



Methodology

A chilled beam's capacity consists of one part provided by the primary air, and a second part supplied by the water.

$$P = P_{pr} + P_{w,r}$$

The primary air-flow rate can be calculated using the graphs numbered II. Likewise, it can be calculated using the following equation.

$$P_{pr} = 1.2 \cdot m_{pr} \cdot \Delta t_{pr}$$

Due to the high capacity of the chilled beams in heating mode, supplementary heat supply through the primary air becomes unnecessary. In these cases, working with an isothermal air discharge is common, i.e. supplying the primary air at the same temperature as the premises ($\Delta t_{pr}=0$).

The technical data associated with each of the chilled beams is determined from the following graphs. From them, it follows that the thermal capacity of the water varies depending on the water flow. This way, once the nominal thermal capacity (P_w), has been defined, the thermal working capacity of the chilled beam is calculated by applying the water flow correction factor (F_w)

Selection example

Let's suppose we have an office with dimensions 3x6x3 and cooling needs of 700 W. The design conditions are defined below:

- Total ventilation level of 80 m³/h
- Primary air temperature of 20 °C.
- Indoor temperature of the room of 26 °C.
- Incoming water temperature of 16 °C.
- Water flow rate of 110 l/h.
- Maximum permissible sound level of 35 dB (A)
- Distance from the floor to the occupation area of 1.8 m.

Calculation

1.- Firstly we determine the primary air flow rate of each of the chilled beams. Using graph V on page 14, we select the nozzle type according to the maximum permissible sound level.

Graph IV: KM nozzle $\rightarrow m_{pr}=80 \text{ m}^3/\text{h} \rightarrow L_{WA}<30 \text{ dBA} \rightarrow P_a = 150 \text{ Pa}$

2.- The nominal cooling capacity of the chilled beam is determined from the primary air flow rate and the temperature difference between the premises reference temperature and the water supply temperature (Δt_{wa}). For this we use graphs V and VI.

Graphs V and VI: KM nozzle $\rightarrow m_{pr}=80 \text{ m}^3/\text{h} \rightarrow \Delta t_{aw}=26 -16 = 10 \text{ }^\circ\text{C} \rightarrow P_w = 550 \text{ W}$

3.- Using diagram III, we calculate the water flow rate modification factor as a function of the selected water flow. In the same way, we obtain the pressure drop of the water circuit.

Graph III: $m_w = 110 \text{ l/h} \rightarrow F_w=1.01 \rightarrow P_{w,r} = P_w * F_w = 550 * 1.01 = 555.5 \text{ W}$

Graph III: $m_w = 110 \text{ l/h} \rightarrow \Delta P_w = 2.3 \text{ kPa}$

4.- Finally, we calculate the air flow rate using diagram II.

Graph II: $m_{pr}=80 \text{ m}^3/\text{h} \rightarrow \Delta t_{pr}=26 -20 = 6 \text{ }^\circ\text{C} \rightarrow P_a = 165 \text{ W}$

5.- This way, the total flow rate contributed by each of the chilled beams will be

$$P=P_{pr}+P_w=555.5 + 165 = 720.5 \text{ W}$$

6.- When we know the water flow rate and selected water flow, we can determine the thermal water gap.

Graph I: $m_w = 110 \text{ l/h} \rightarrow P_w=720.5 \rightarrow \Delta t_w = 5.5 \text{ }^\circ\text{C}$

7.- Finally, the air range values are calculated from the aerodynamic data charts of the 900 WAAB SUITE 2T beam.

Range to wall (V_L):

Using the graph on page 15, we calculate the distance at which the air reaches 0.2m/s according to the type of nozzle and the air flow rate.

$$m_{pr}= 80 \text{ m}^3/\text{h} \rightarrow \text{M nozzle} \rightarrow L_{(0.2\text{m/s})} = 5\text{m}$$

COOLING TECHNICAL DATA 2 PIPES

WAAB SUITE 900

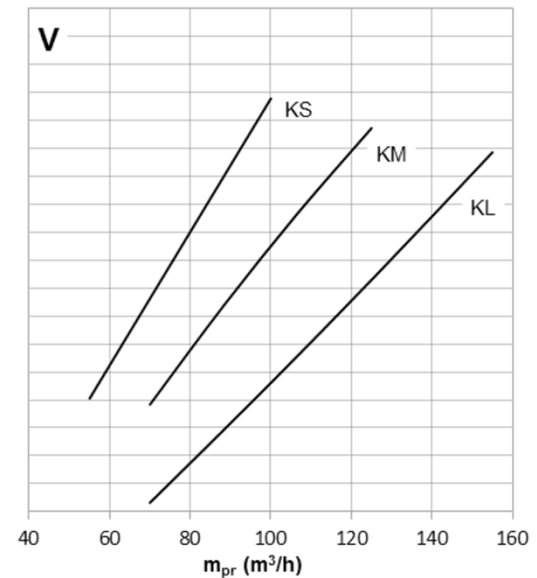
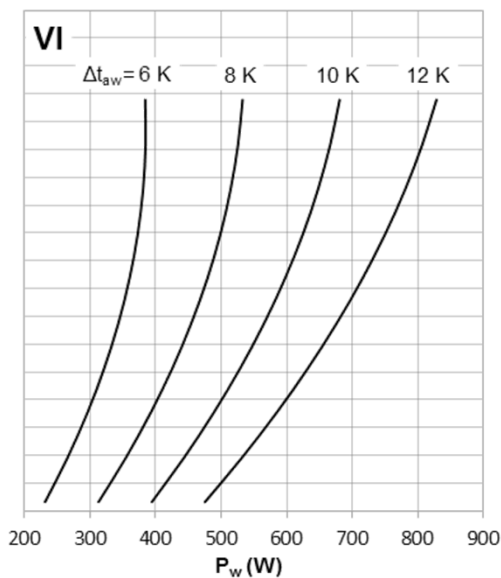
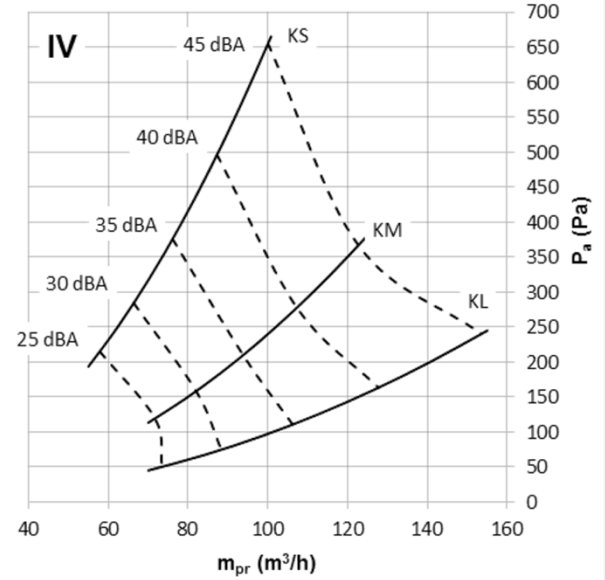
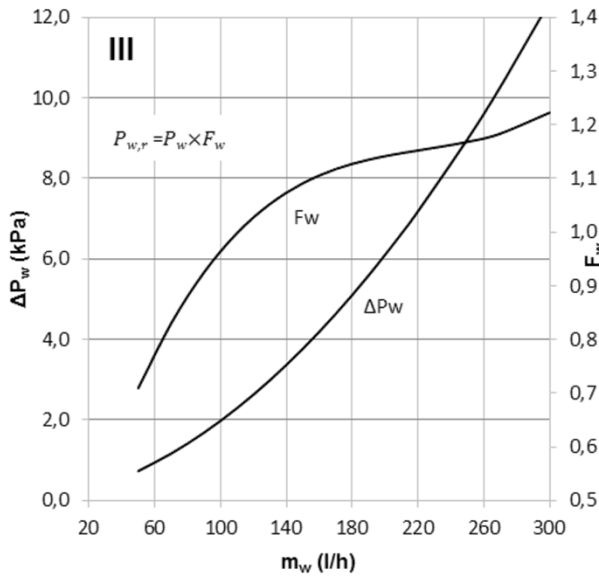
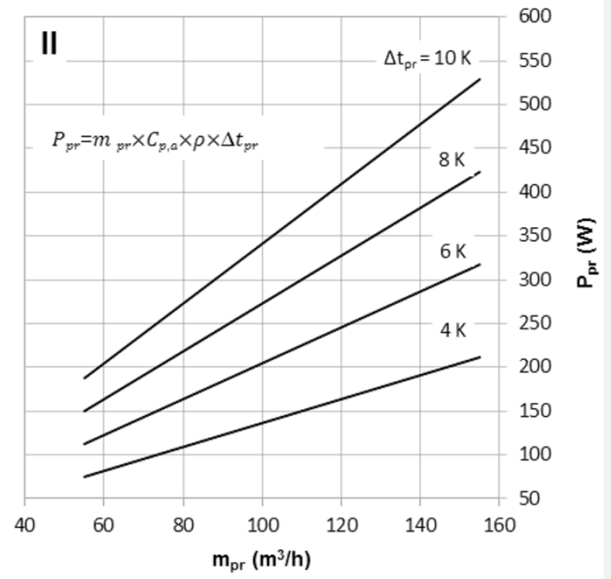
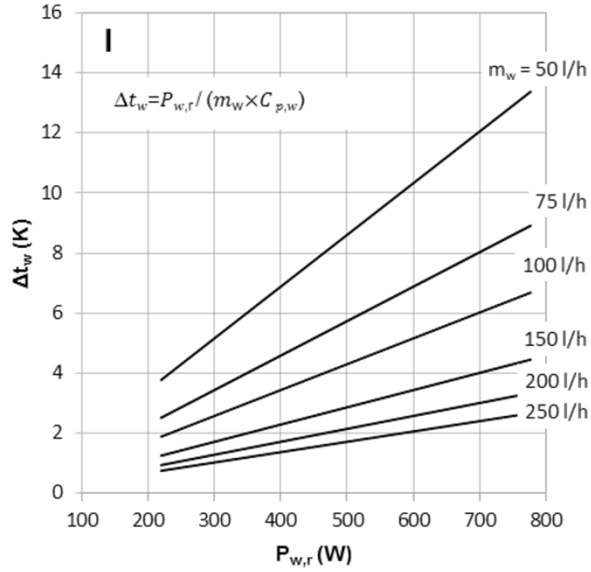

COOLING TECHNICAL DATA 4 PIPES

WAAB SUITE 900

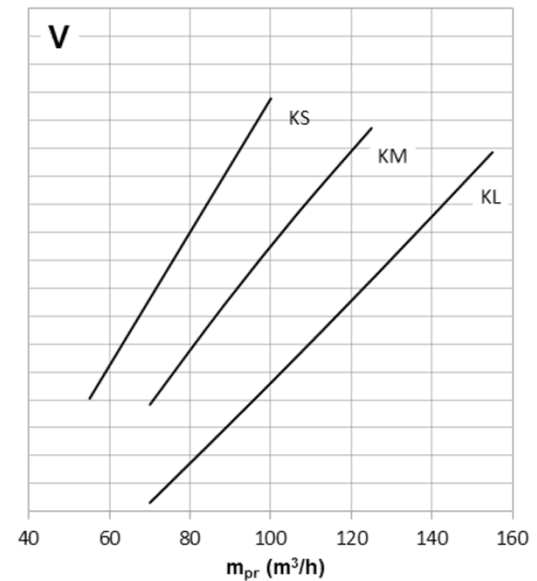
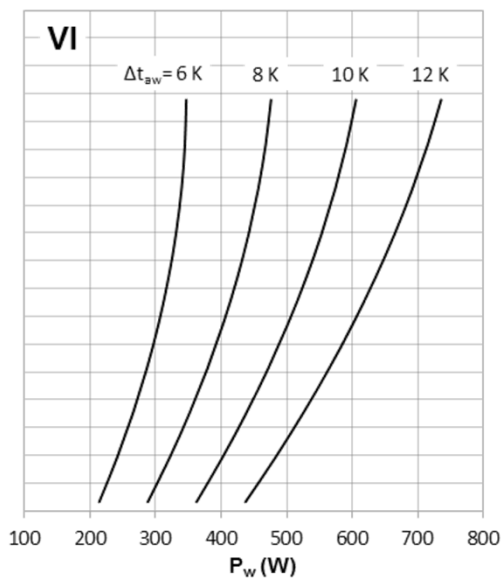
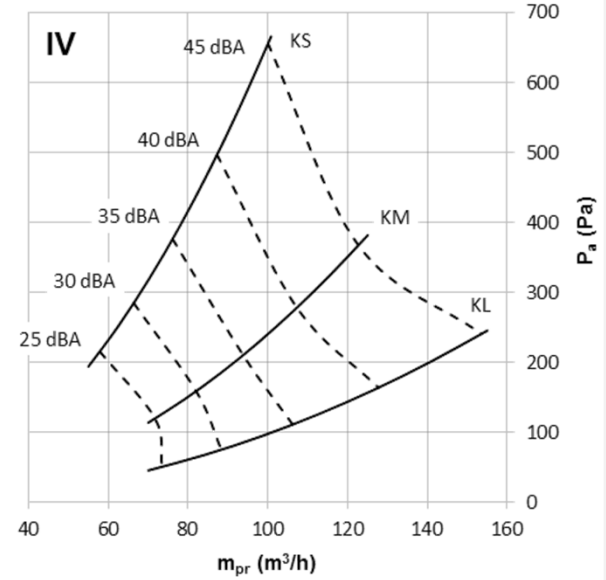
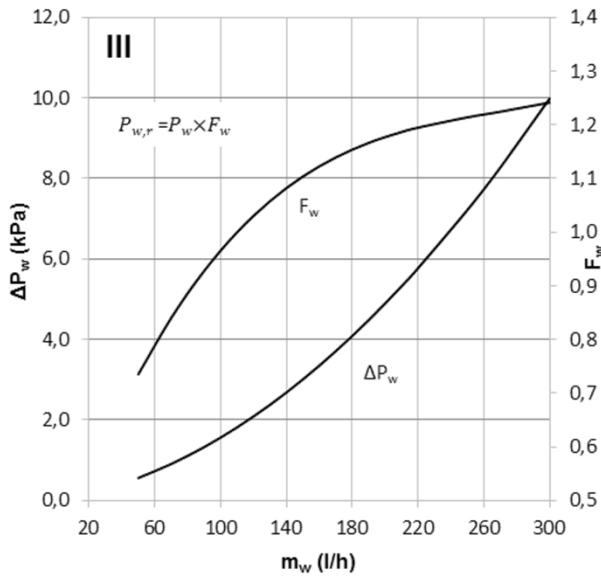
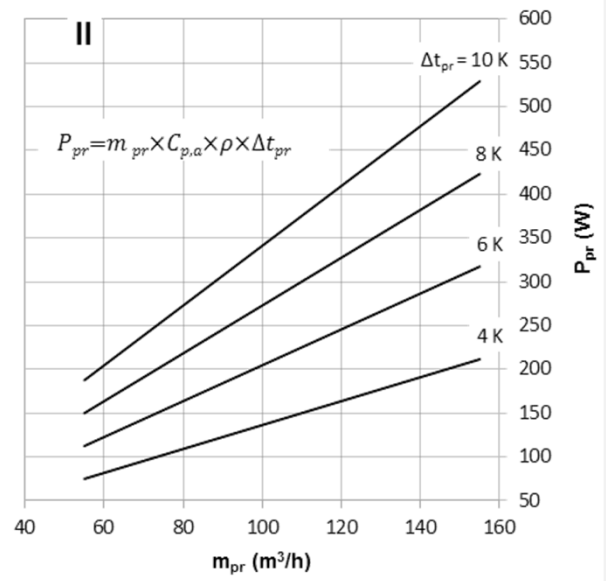
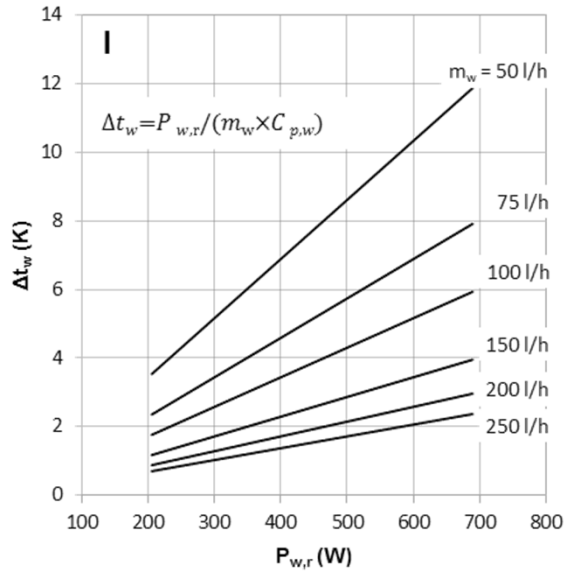

HEATING TECHNICAL DATA 2 PIPES

WAAB SUITE 900

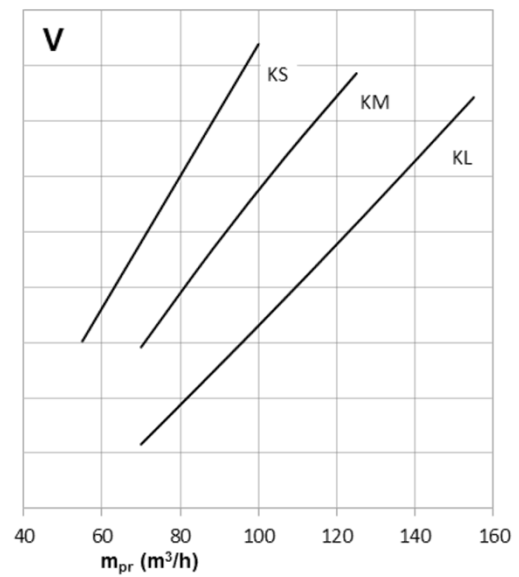
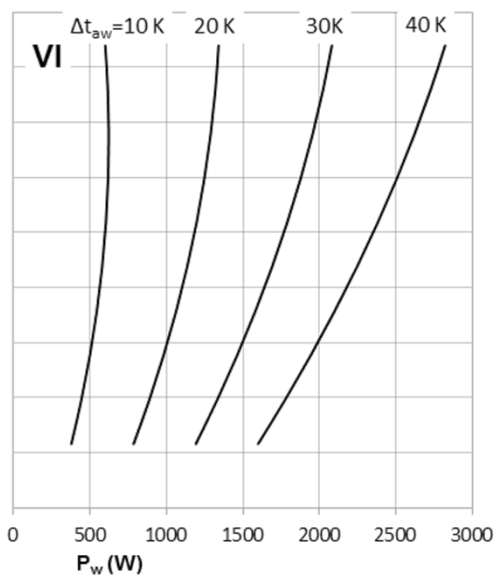
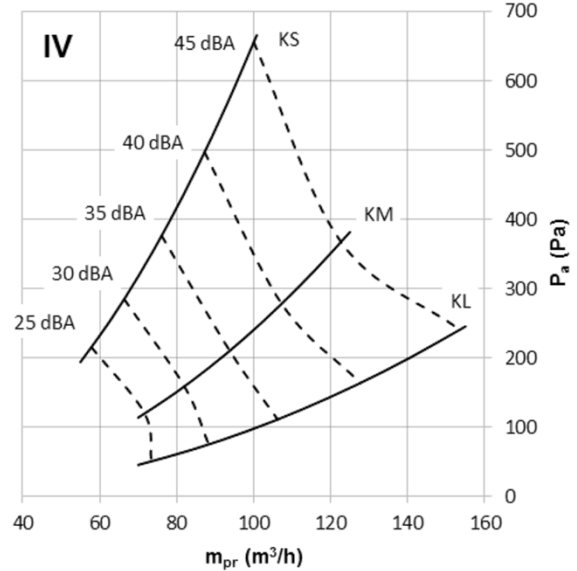
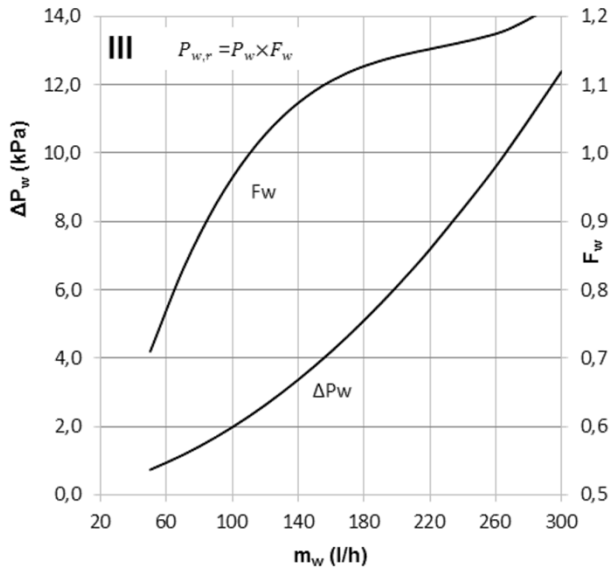
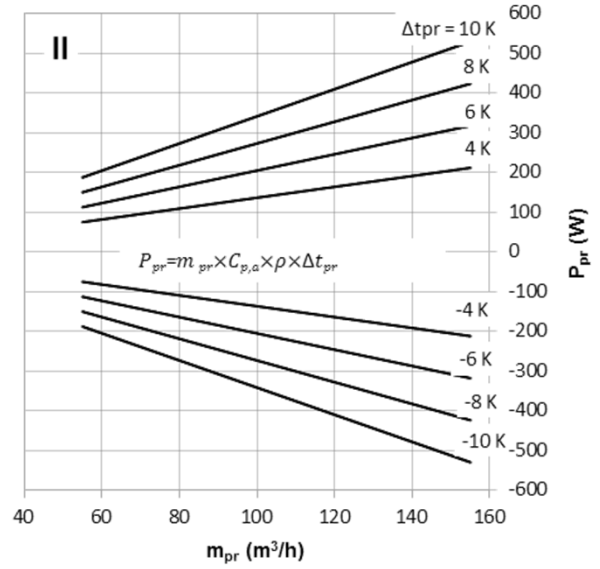
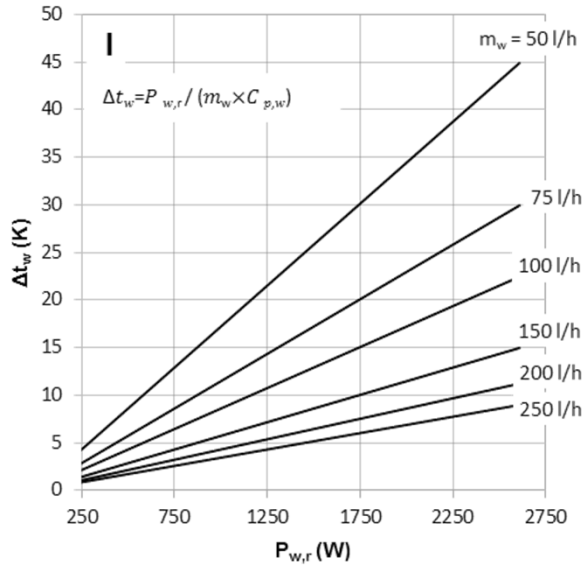

HEATING TECHNICAL DATA 4 PIPES

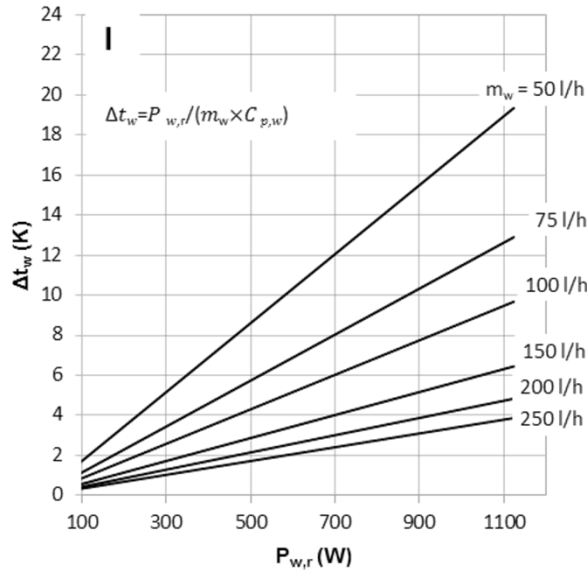

WAAB SUITE 900

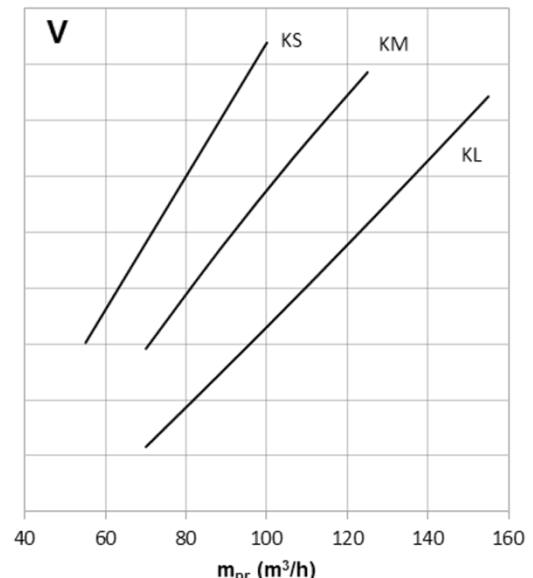
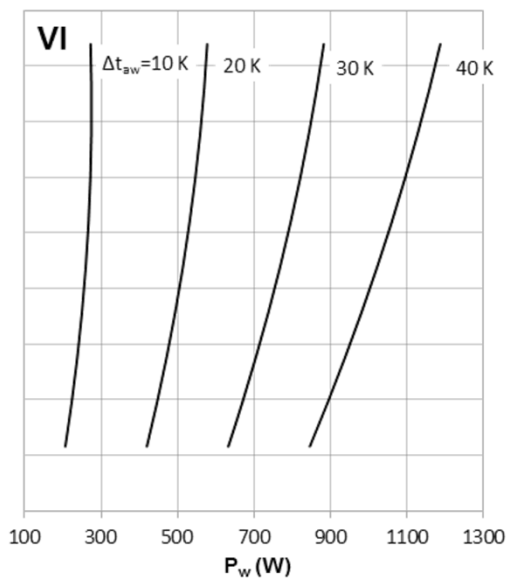
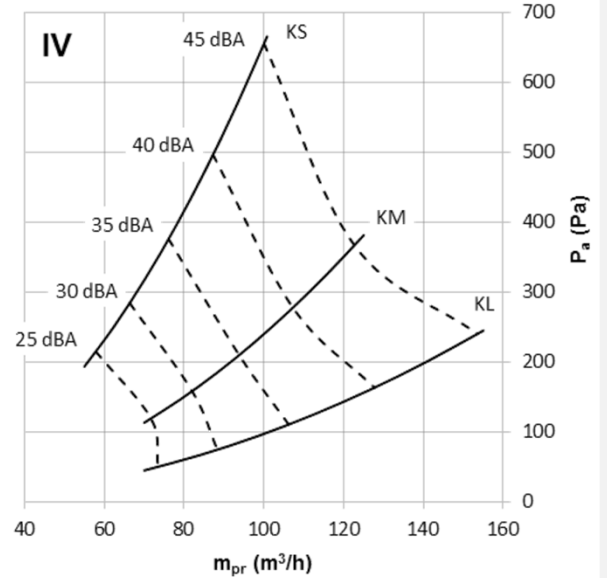
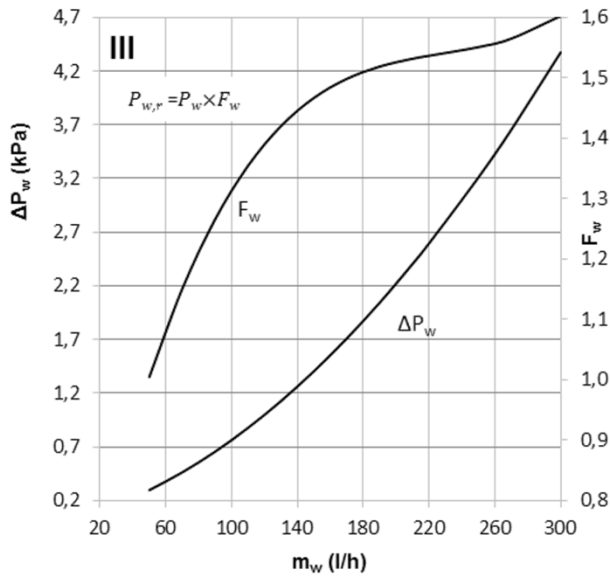
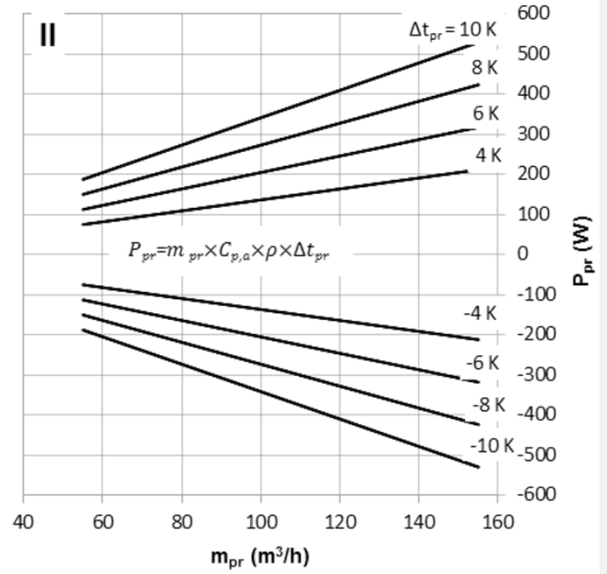

BEAM-WALL AERODYNAMIC DATA

WAAB SUITE

WAAB SUITE 900 Nozzle P

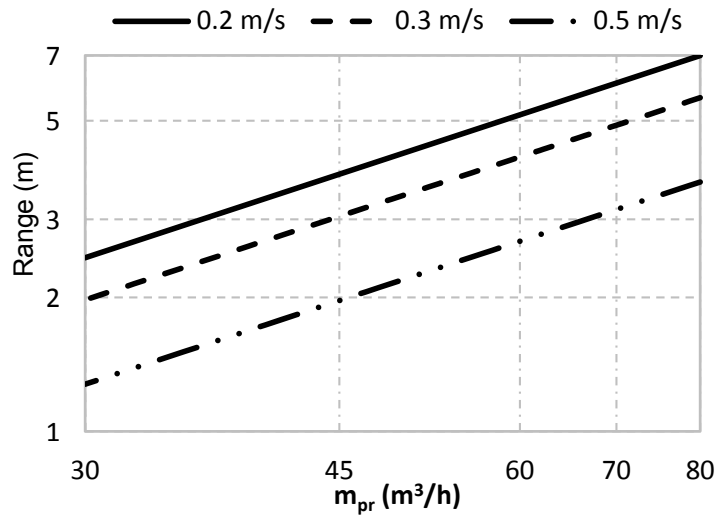

WAAB SUITE 900 Nozzle M

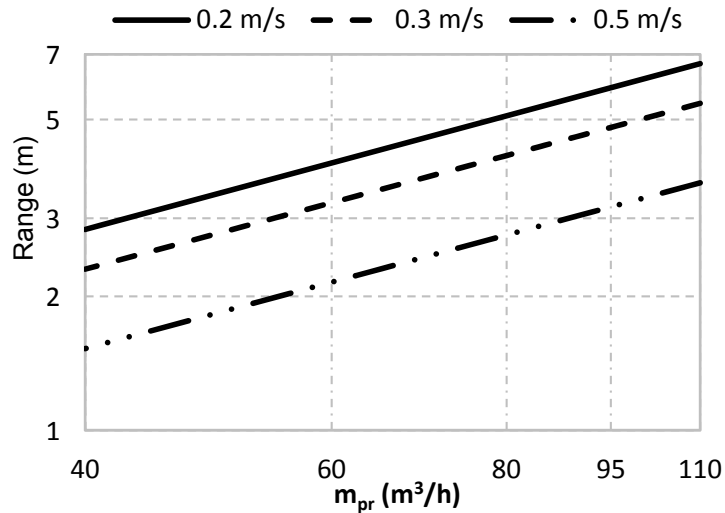

WAAB SUITE 900 Nozzle G

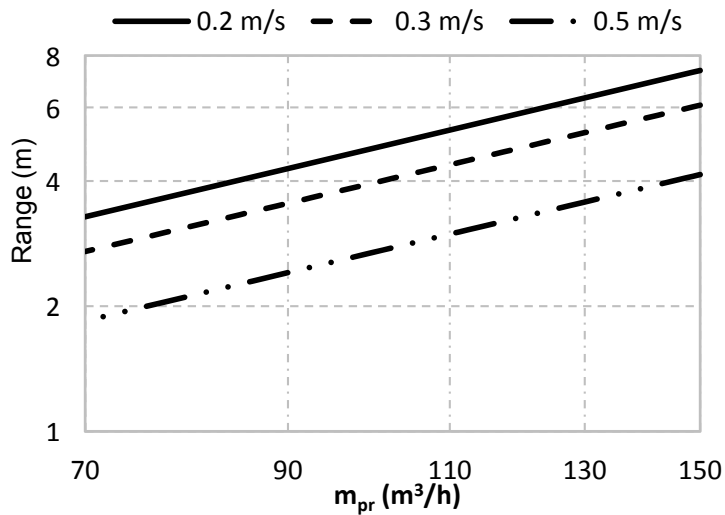

COOLING TECHNICAL DATA 2 PIPES

WAAB SUITE 900

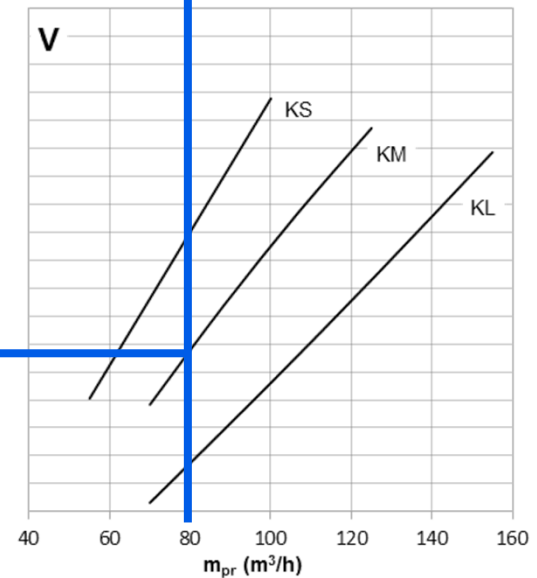
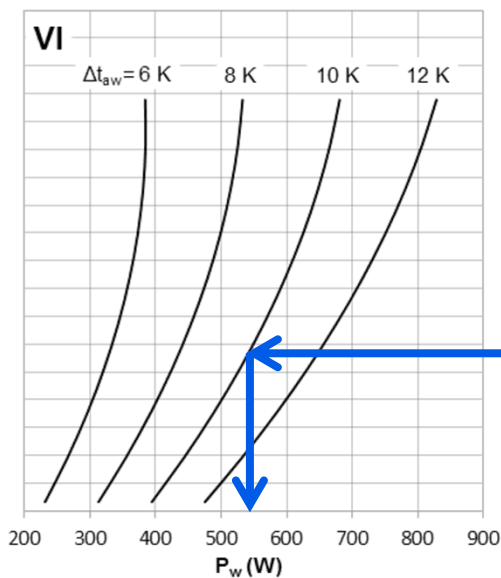
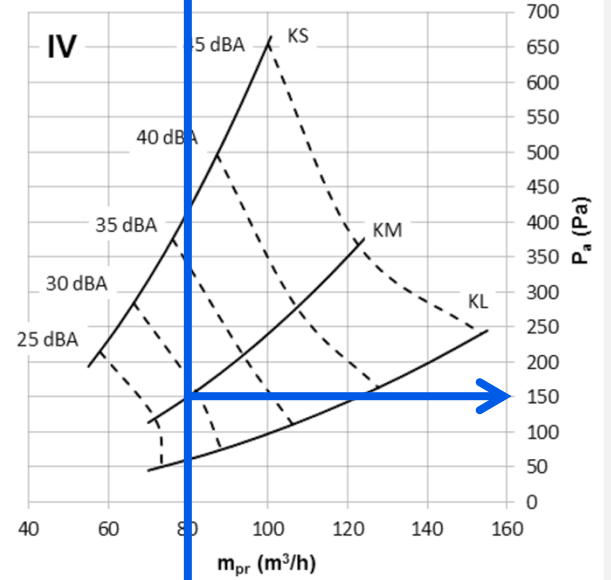
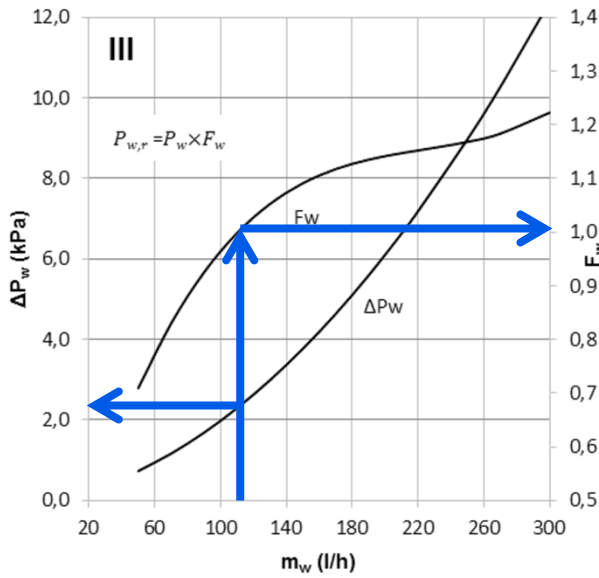
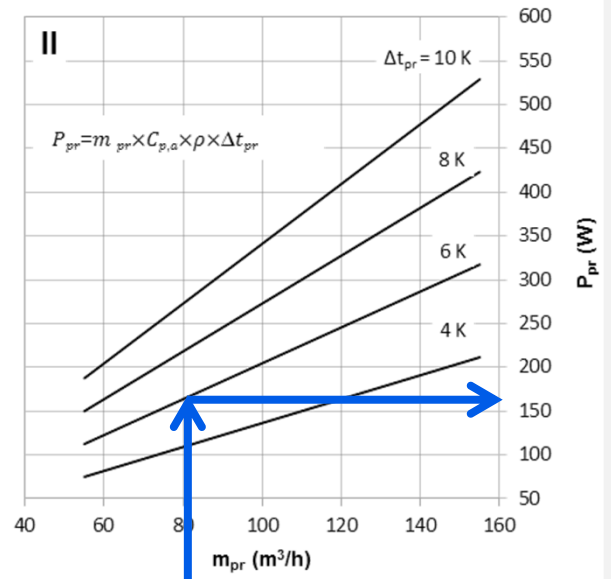
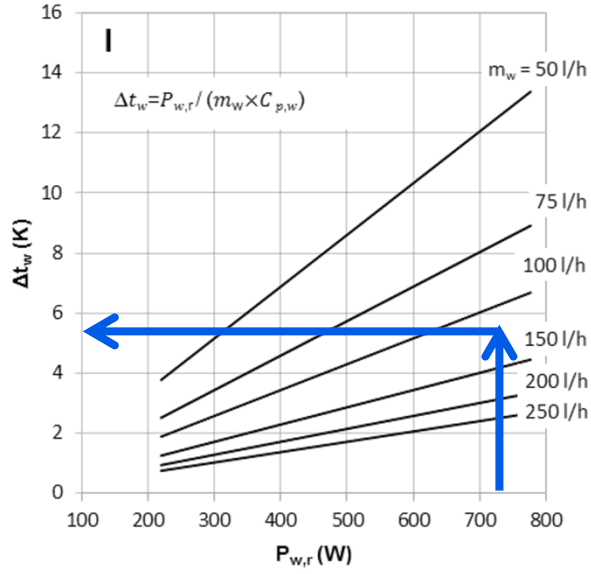

BEAM-WALL AERODYNAMIC DATA

WAAB SUITE

WAAB SUITE 900 Nozzle P

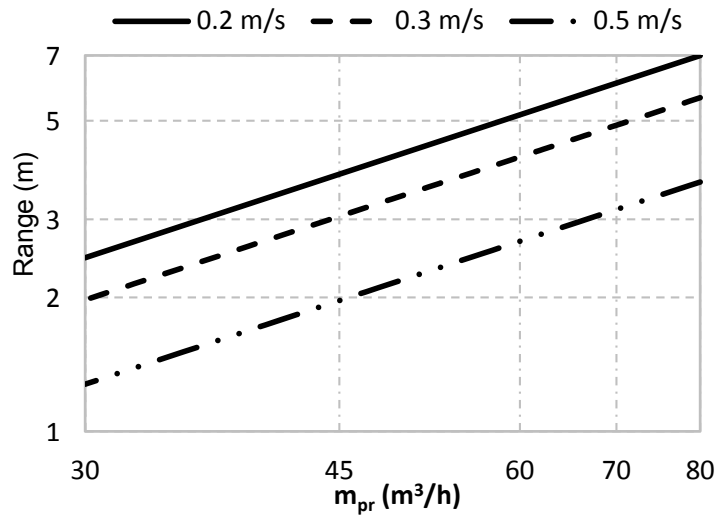

WAAB SUITE 900 Nozzle M

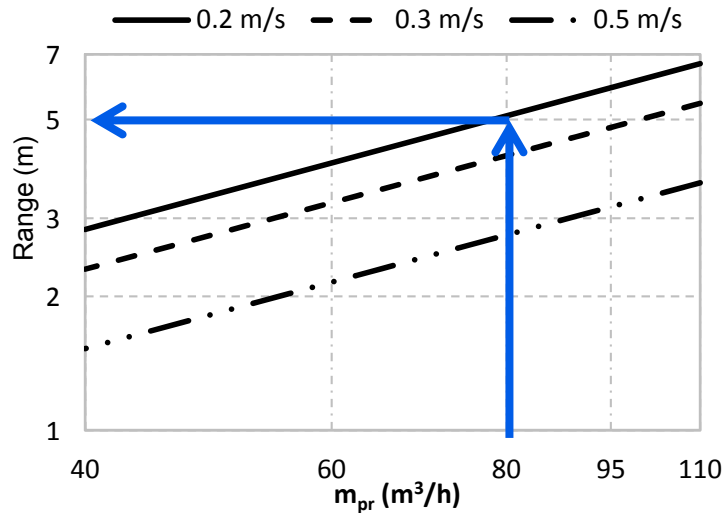

WAAB SUITE 900 Nozzle G

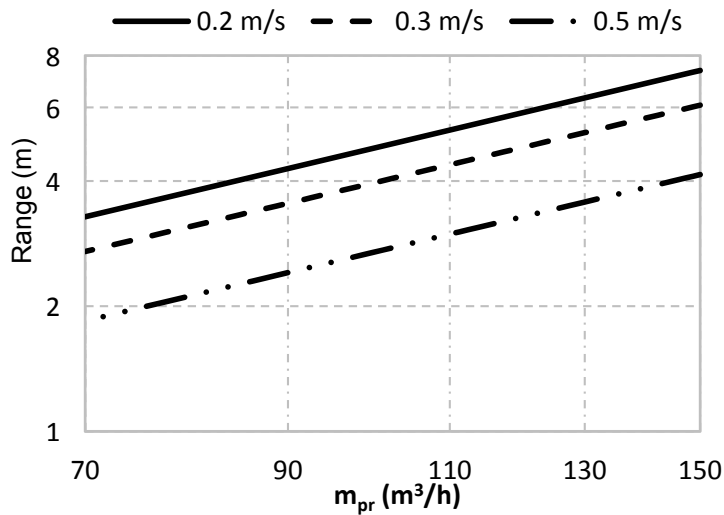

COOLING TECHNICAL DATA 2 PIPES

WAAB SUITE 1200

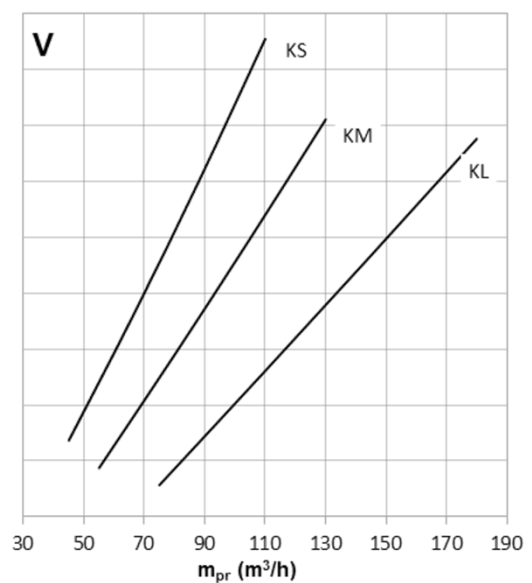
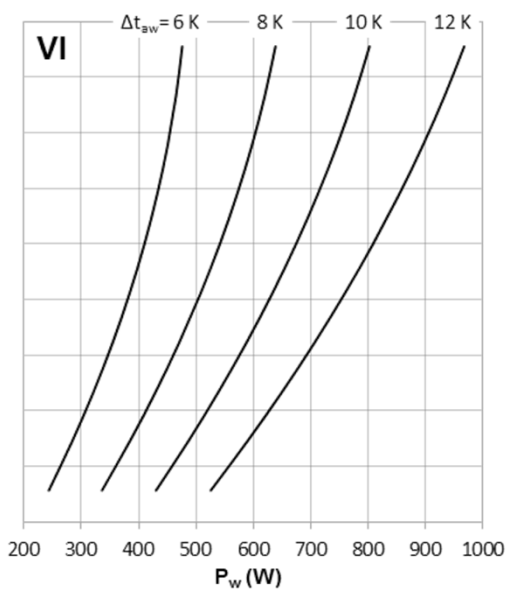
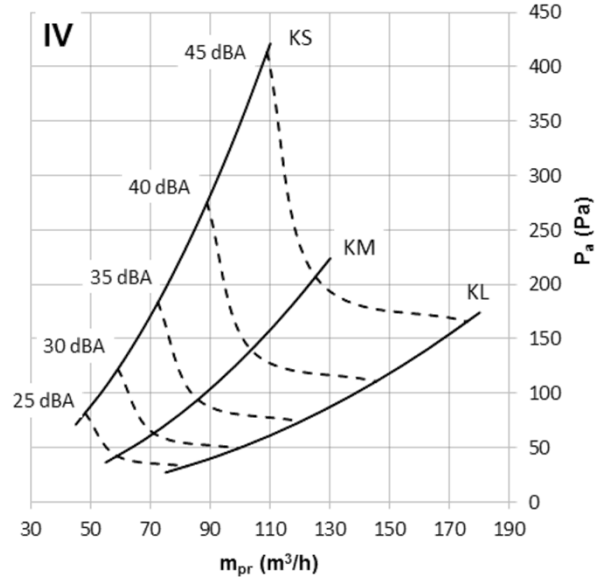
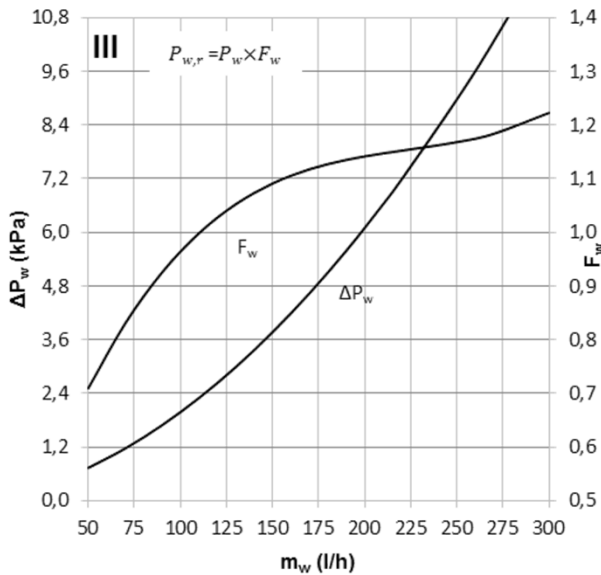
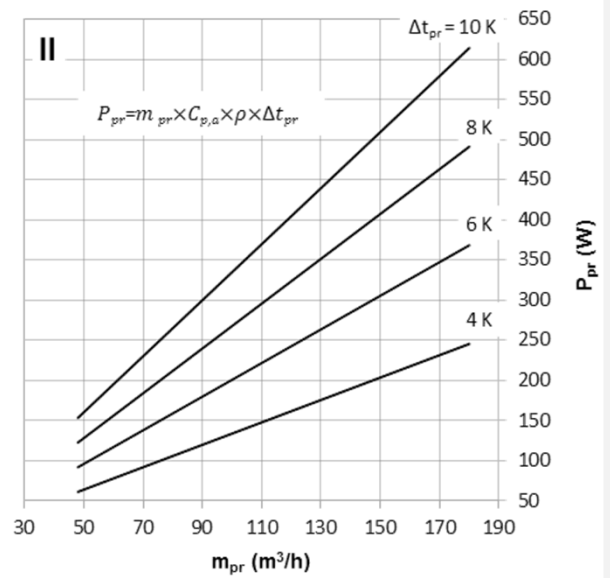
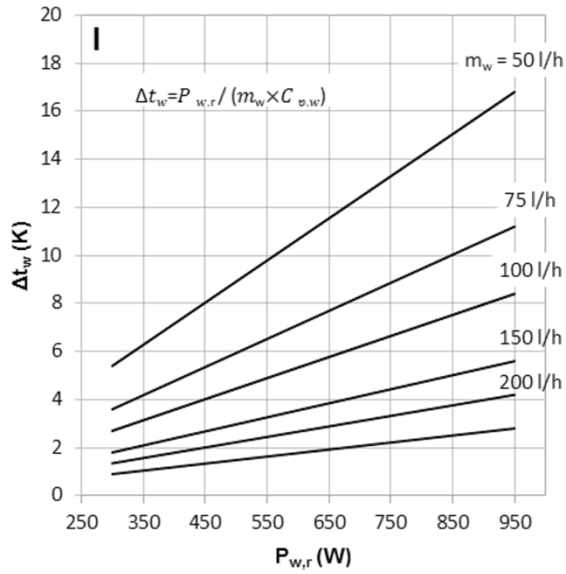

COOLING TECHNICAL DATA 4 PIPES

WAAB SUITE 1200

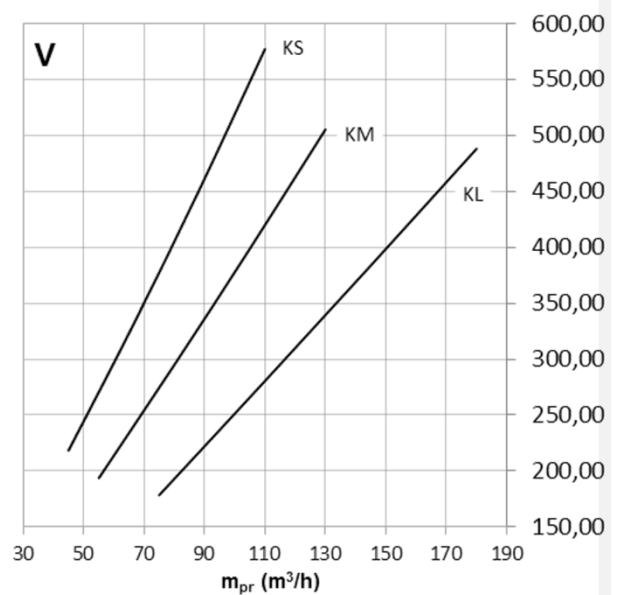
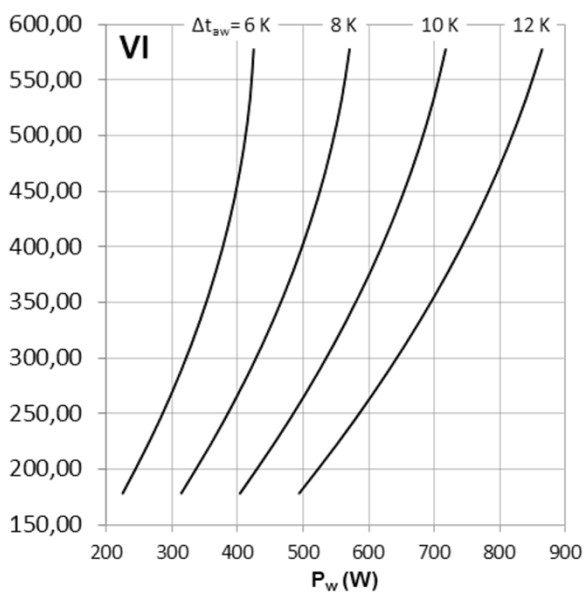
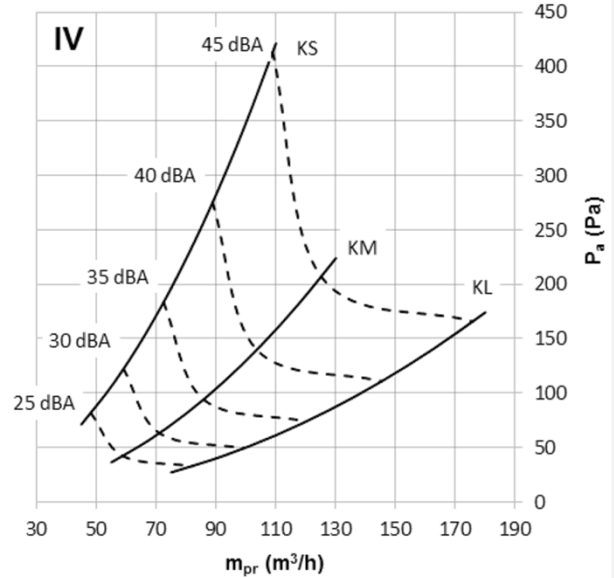
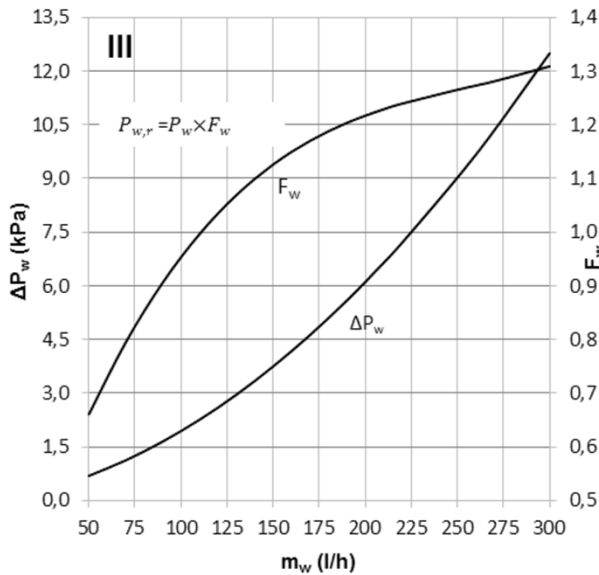
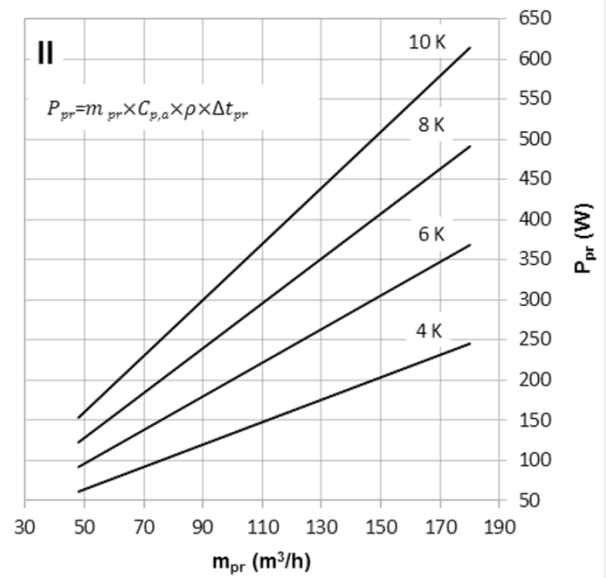
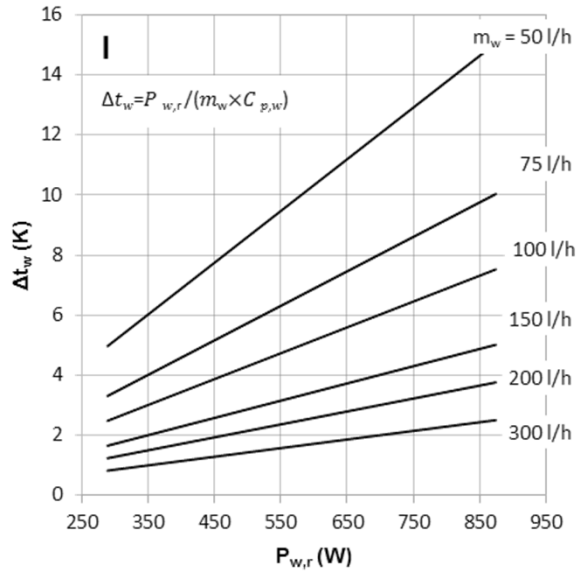

HEATING TECHNICAL DATA 2 PIPES

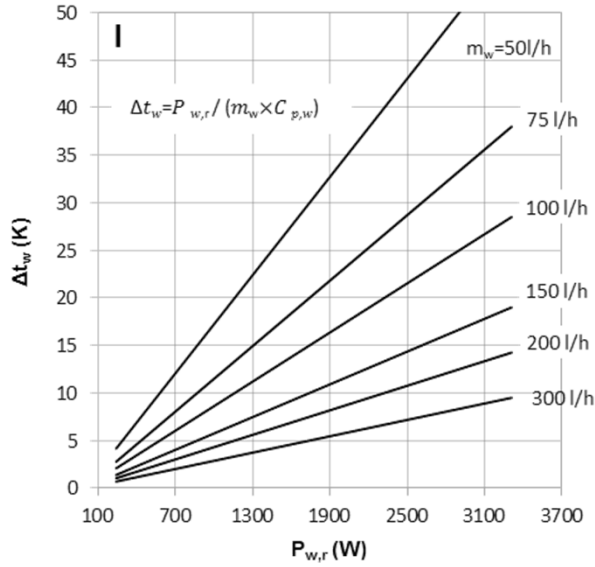

WAAB SUITE 1200

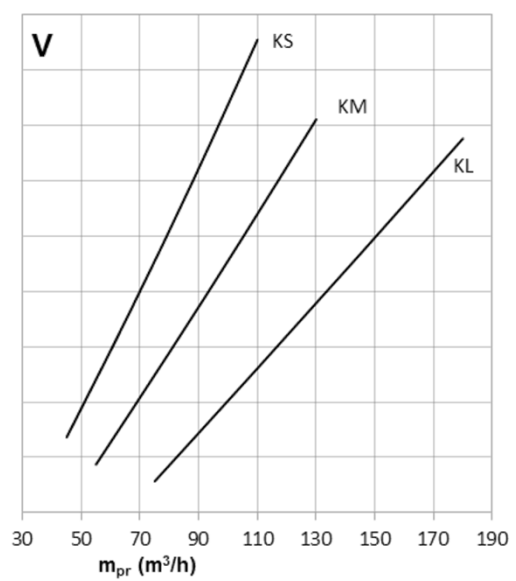
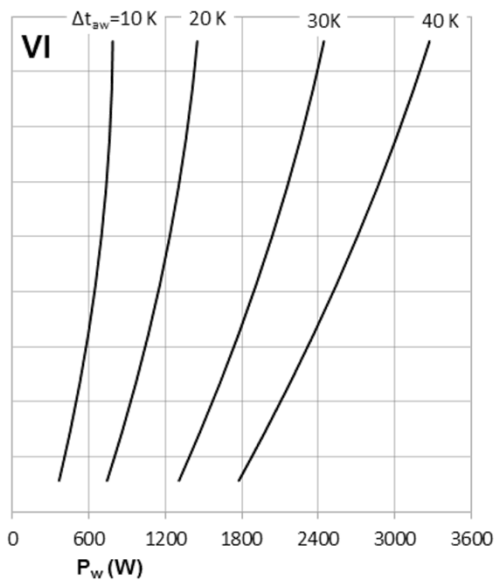
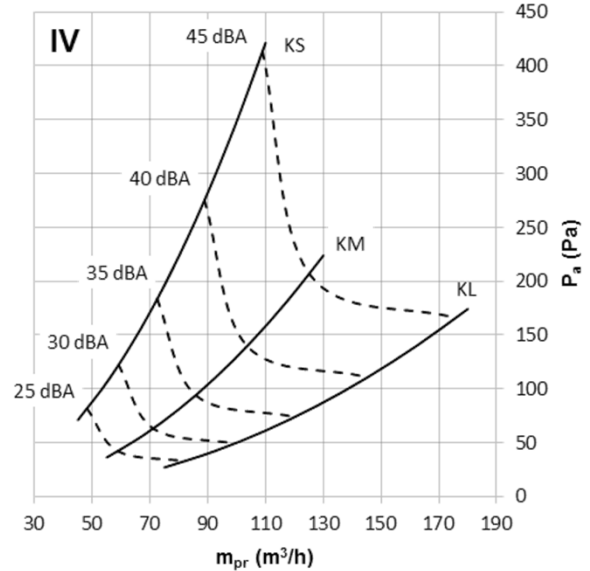
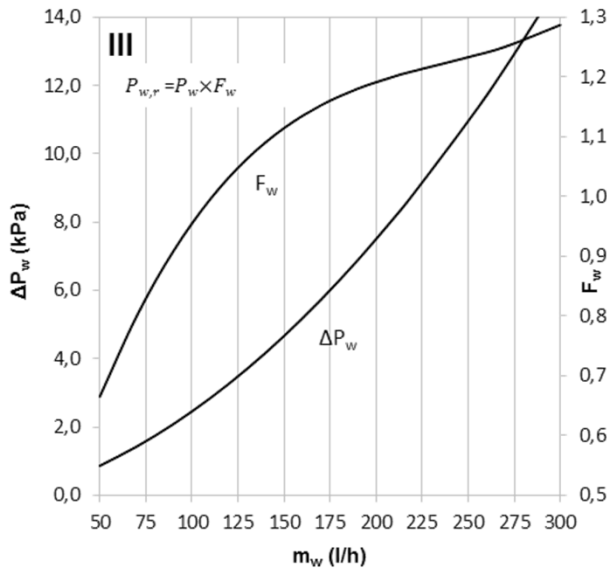
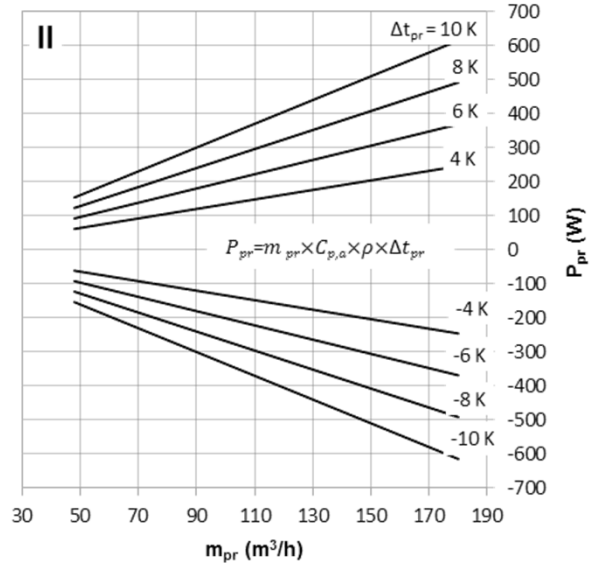

HEATING TECHNICAL DATA 4 PIPES

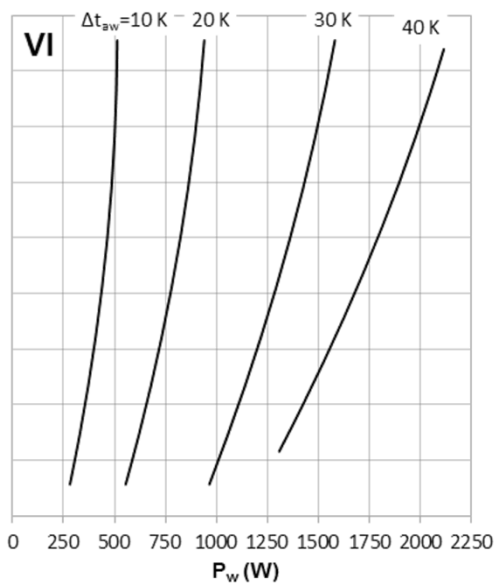
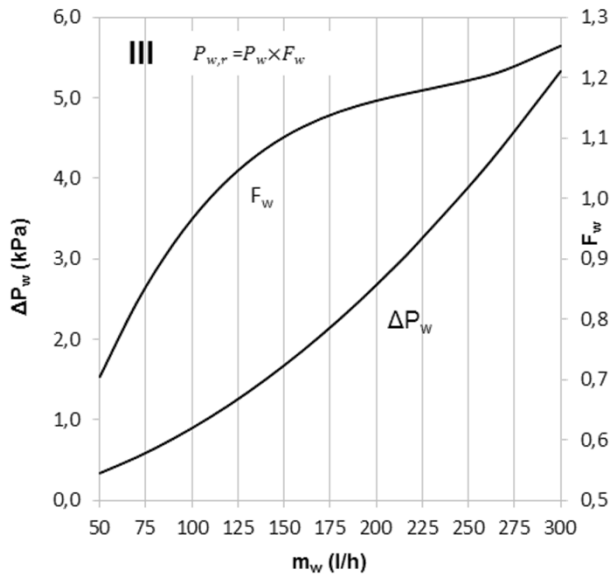
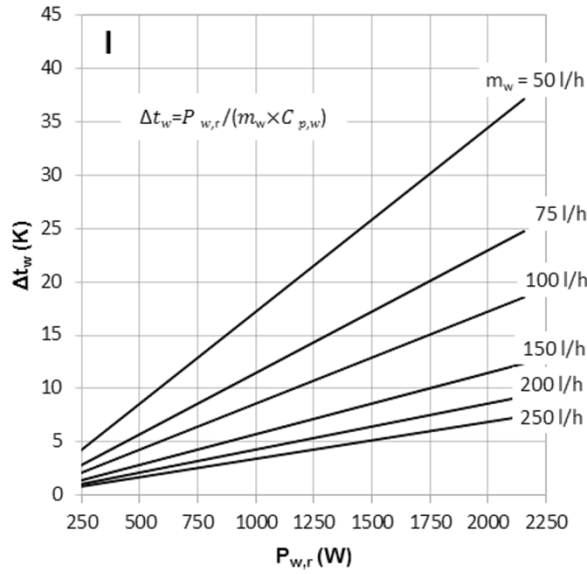

WAAB SUITE 1200

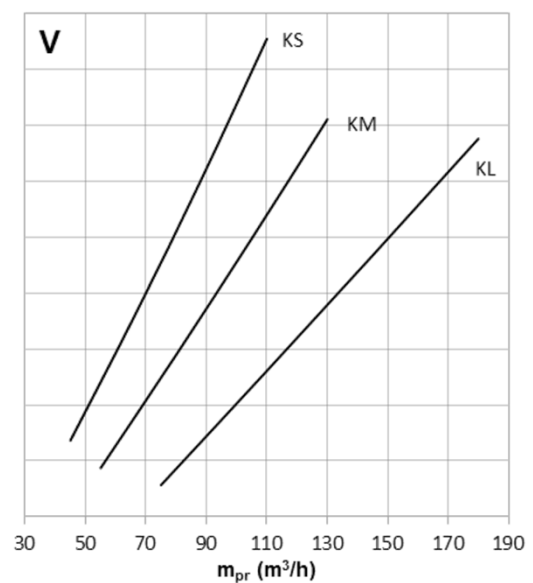
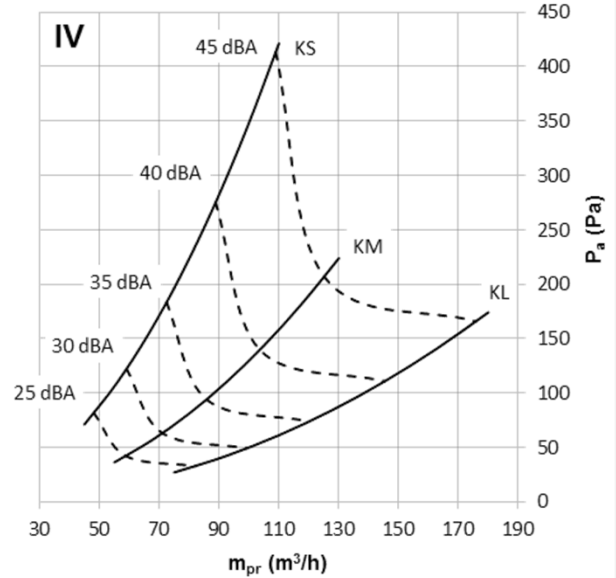
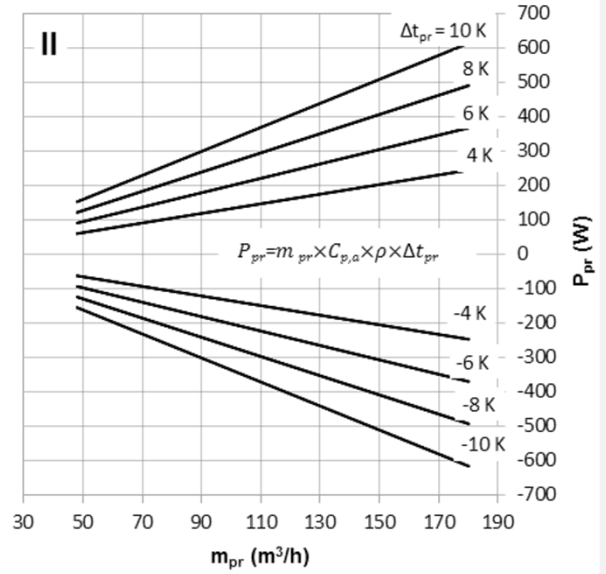

BEAM-WALL AERODYNAMIC DATA

WAAB SUITE 1200

WAAB SUITE 1200 Nozzle P

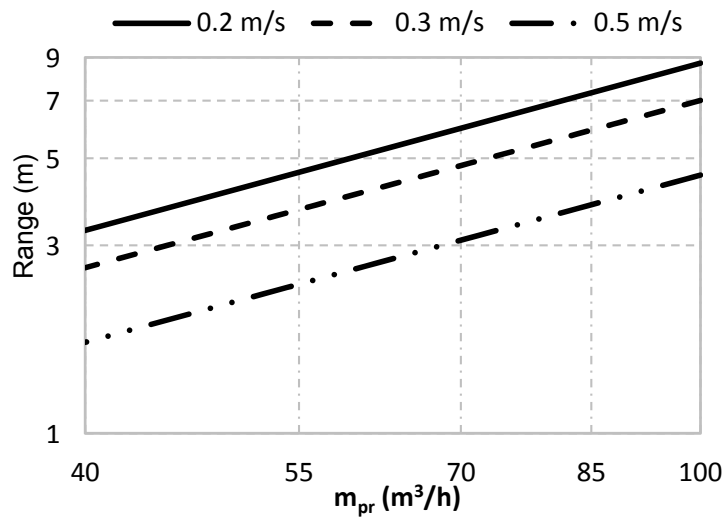

WAAB SUITE 1200 Nozzle M

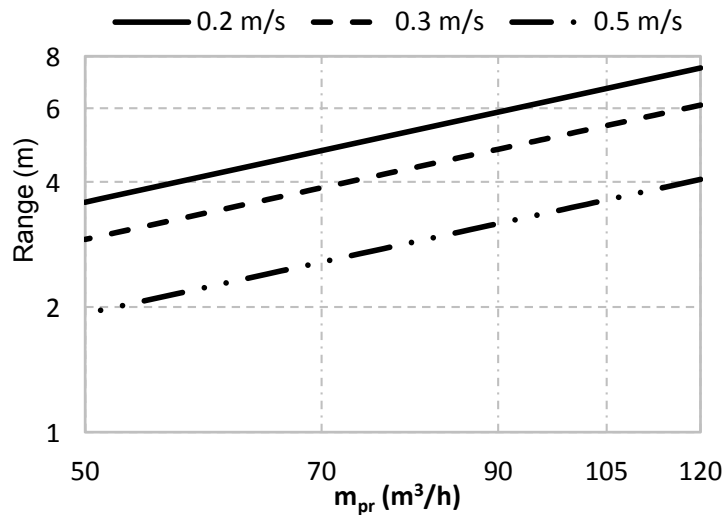

WAAB SUITE 1200 Nozzle G

